

TECHNICAL MANUAL

DIRECT SUPPORT MAINTENANCE MANUAL
(INCLUDING REPAIR PARTS AND SPECIAL TOOLS LIST)

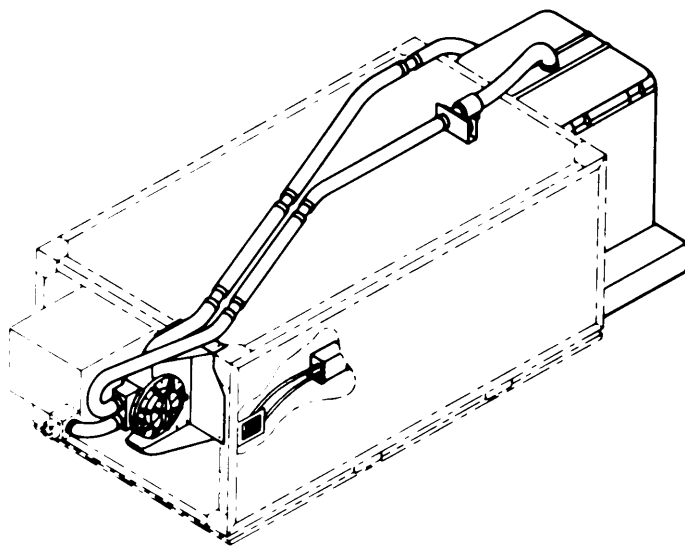

INTRODUCTION	1-1
TROUBLESHOOTING	2-1
MAINTENANCE PROCEDURES FOR M12 PROTECTIVE ENTRANCE	2-137
MAINTENANCE PROCEDURES FOR M56 GAS-PARTICULATE FILTER UNIT	2-144
REPAIR PARTS AND SPECIAL TOOLS LIST	B-1
EXPENDABLE SUPPLIES AND MATERIALS LIST	C-1
INDEX	INDEX-1

COLLECTIVE PROTECTION EQUIPMENT, GUIDED MISSILE AIR
DEFENSE SYSTEM, AN/TSQ-73
CONSISTING OF
ENTRANCE, PROTECTIVE, PRESSURIZED: COLLAPSIBLE, M12
(NSN 4240-01-048-2923);
FILTER UNIT, GAS-PARTICULATE: 200 CFM, 208 V, 400 HZ, M56
(NSN 4240-00-237-0227)
AND
INSTALLATION KIT: CBR, PROTECTIVE EQUIPMENT, AN/TSQ-73, M263
(NSN 4240-01-063-7679)

HEADQUARTERS, DEPARTMENT OF THE ARMY
24 AUGUST 1982

TECHNICAL MANUAL

No. 3-4240-286-30&P

HEADQUARTERS
DEPARTMENT OF THE ARMY
WASHINGTON, DC, 24 August 1982

Direct Support Maintenance Manual
(Including Repair Parts And Special Tools List)

COLLECTIVE PROTECTION EQUIPMENT, GUIDED MISSILE AIR
DEFENSE SYSTEM, AN/TSG-73

CONSISTING OF

ENTRANCE, PROTECTIVE, PRESSURIZED: COLLAPSIBLE, M12
(NSN 4240-01-048-2923);

FILTER UNIT, GAS-PARTICULATE:

200 CFM, 208 V, 400 HZ, M56

(NSN 4240-00-237-0227)

AND

INSTALLATION KIT: CBR, PROTECTIVE EQUIPMENT, AN/TSG-73, M283

(NSN 4240-01-063-7679)

Current as of 3 March 1982 for Appendix B.

REPORTING ERRORS AND RECOMMENDING IMPROVEMENTS

You can help improve this manual. If you find any mistakes or if you know of a way to improve the procedures, please let us know. Mail your letter, DA Form 2028 (Recommended Changes to Publications and Blank Forms), or DA Form 2028-2 located in the back of this manual direct to: Commander, US Army Armament Materiel Readiness Command, ATTN: DRSAR-MAS-C, Aberdeen Proving Ground, MD21010. A reply will be furnished to you.

		Page
CHAPTER	1 INTRODUCTION	1-1
Section I	General Information	1-1
II	Equipment Description and Data	1-2
III	Repair Parts, Special Tools, TMDE, and Support Equipment	1-2
Iv	Principles of Operation	1-2

		Page	
CHAPTER	2	MAINTENANCE INSTRUCTIONS	2-1
Section	I	Troubleshooting	2-1
	II	Maintenance Procedures for M12 Protective Entrance	2-137
	III	Maintenance Procedures for M56 Gas-Particulate Filter Unit	2-144
APPENDIX	A	REFERENCES	A-1
	B	REPAIR PARTS AND SPECIAL TOOLS LIST	B-1
Section	I	Introduction	B-1
	II	Repair Parts List	B-6
			Page
Group	0100	M12 Protective Entrance	B-7
		0110 Protective Entrance Control Module	B-11
	0200	M56 Gas-Particulate Filter Unit	B-14
		0210 Main Fan	B-21
		0220 Airflow Valve	B-23
		0230 Power Distribution Unit	B-25
		0231 Power Distribution Panel	B-29
		0240 Compartment Control Module	B-35
	0300	M263 Installation Kit	B-39
		0310 Airflow Valve and Silencer	B-41
		0311 Airflow Valve	B-43
	0500	Bulk Material	B-44
Section	III	Special Tools List (Not Applicable)	
	Iv	NSN, Part No. index	B-45
APPENDIX	C	EXPENDABLE SUPPLIES AND MATERIALS LIST	C-1
	D	ILLUSTRATED LIST OF MANUFACTURED ITEMS	D-1
		INDEX	Index 1

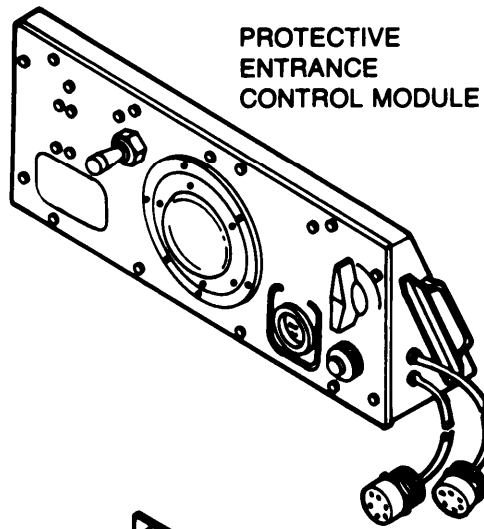

PROTECTIVE
ENTRANCE
CONTROL MODULE

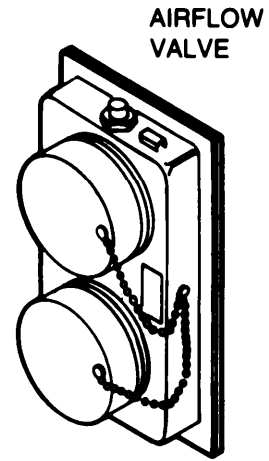

AIRFLOW
VALVE

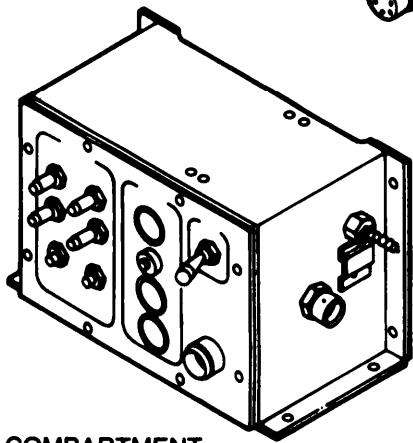

COMPARTMENT
CONTROL MODULE

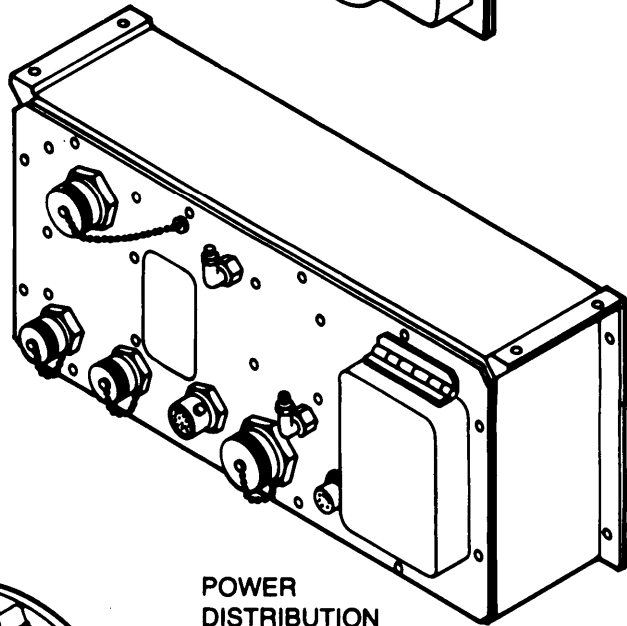

POWER
DISTRIBUTION
UNIT

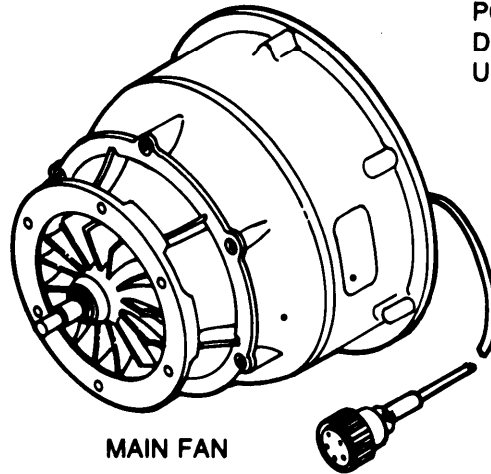

MAIN FAN

CHAPTER 1

INTRODUCTION

Section I. GENERAL INFORMATION

1-1. SCOPE.

a. Type of *Manua/*. Direct Support Maintenance, including the Repair Parts and Special Tools List.

b. *Model Numbers and Equipment Names*.

M12 protective entrance:

Protective entrance control module

M56 gas-particulate filter unit:

Main fan

Airflow valve

Power distribution unit

Compartment control module

M263 installation kit:

Airflow valve

c. *Purpose of Equipment*. Provides filtered air under positive pressure to field shelters.

1-2. MAINTENANCE FORMS, RECORDS, AND REPORTS. Department of the Army forms and procedures used for equipment maintenance will be those prescribed by TM 38-750, The Army Maintenance Management System (TAMMS).

1-3. DESTRUCTION OF ARMY MATERIEL TO PREVENT ENEMY USE. Refer to TM 43-0002-31, Destruction of Chemical Weapons and Defense Equipment to Prevent Enemy Use.

1-4. NOMENCLATURE CROSS-REFERENCE LIST. This listing includes nomenclature cross-references used in this manual.

<i>Common Name</i>	<i>Official Nomenclature</i>
Compartment control module (CCM)	Control module, compartment

<i>Common Name</i>	<i>Official Nomenclature</i>
Differential pressure gage	Gage, differential, dial indicating
M56 gas-particulate filter unit	Filter unit, gas-particulate, M56
M12 protective entrance	Entrance, protective, pressurized, M12
M263 installation kit	Installation kit, M263
Power card	Printed circuit board: power
Protective entrance control module (PECM)	Control module, protective entrance
Switching card	Printed circuit board: switching

1-5. REPORTING EQUIPMENT IMPROVEMENT RECOMMENDATIONS (EIR). If your collective protection equipment needs improvement, let us know. Send us an EIR. You, the user, are the only one who can tell us what you don't like about your equipment. Let us know why you don't like the design. Tell us why a procedure is hard to perform. Put it on an SF 368 (Quality Deficiency Report). Mail it to us at Commander, US Army Armament Materiel Readiness Command, ATTN: DRSAR-MAP-A, Aberdeen Proving Ground, MD21010. A reply will be furnished directly to you.

Section II. EQUIPMENT DESCRIPTION AND DATA

1-6. DESCRIPTION AND TABULATED DATA. Refer to TM 3-4240-286-20&P.

Section III. REPAIR PARTS, SPECIAL TOOLS, TMDE, AND SUPPORT EQUIPMENT

1-7. COMMON TOOLS AND EQUIPMENT. For authorized common tools and equipment refer to the Modified Table of Organization and Equipment (MTOE) applicable to your unit.

1-8. SPECIAL TOOLS, TMDE, AND SUPPORT EQUIPMENT. No special tools, TMDE, or support equipment are required.

1-9. REPAIR PARTS. Repair parts are listed and illustrated in appendix B of this manual.

Section IV. PRINCIPLES OF OPERATION

1-10. PRESSURE CONTROL SYSTEM.

a. The basic function of the pressure control system is to control the air pressure in a protected compartment within the prescribed limits by controlling the opening of an airflow valve from the pressurized air supply, the filter unit. The prescribed limits are 1.2 to 1.7 inches water gage (hereafter referred to as in. wg) for the compartment or compartment control module and 0.4 to 0.8 in. wg for the protective entrance and protective entrance control module. The control system operates from 28 vdc power.

b. The compartment pressure is sensed by the pressure transducer which provides an output voltage of 2 volts/in. wg to pin 1 of the switching card. When the air pressure in the compartment drops below the desired low limit, 1.2 in. wg for switching card A2 or 0.4 in. wg for

switching card A3, the pressure transducer output voltage drops below the low limit reference voltage. An operational amplifier (op amp) on the switching card compares pressure transducer output voltage to the low limit reference voltage (2.6 volts for the compartment control module low limit side) provided by potentiometer R11, resistor R13 and the voltage reference diode VR1 and multiplies the voltage difference by 26 times and provides this as the output voltage at TP-D. The op amp output voltage is at a low power level of only a few milliamps (mA). The transistor Q1 amplifies the power level to about 50 mA while providing no voltage amplification. The power level is further amplified by Q4 of the power card A1. This transistor brings the power level up to about 500 mA to drive the airflow valve motor.

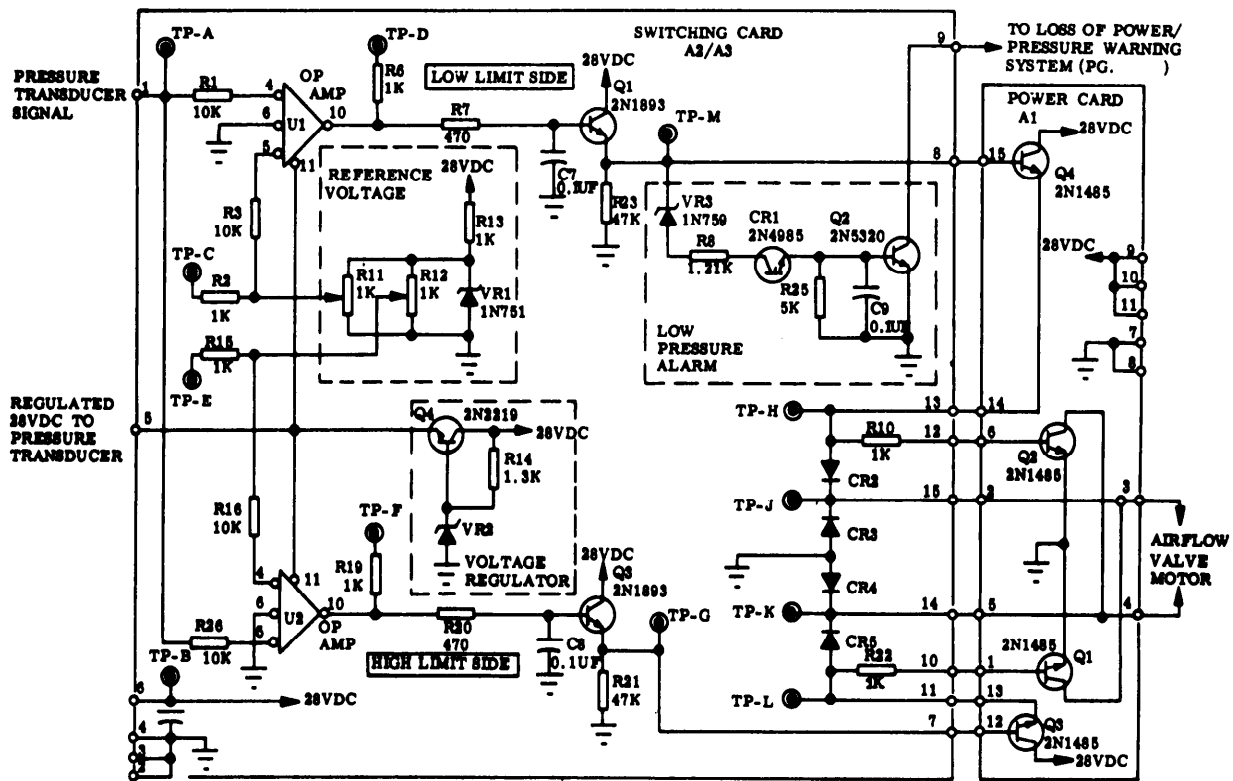

Pressure Control System, Switching and Power Card, Interconnection Schematic

c. Direct current power and ground are provided at output terminals 3 and 4 of the 'power card' to the reversible 28 vdc motor. As the output of Q4 on the power card starts to rise, it provides current via R10 to the base of Q2 on the power card. When this happens, Q2 turns on and provides a ground at terminal 4 of the power card whenever a voltage greater than a few volts is provided at terminal 3 of the power card. The airflow valve motor is connected such that when this happens the airflow valve motor will start and open the valve until the compartment pressure has risen to within the prescribed limits.

d. The description so far has been only for a low pressure condition or low limit side. There is an equivalent high pressure or high limit side circuitry which provides opposite polarity voltage to terminals 3 and 4 of the power card and hence the airflow valve motor. This circuitry consists of U2, Q3 on the switching card, and Q3 and Q1 on the power card. Whenever one pressure side is on, the other side is off. In the dead band (i.e., when the pressure is within the proper limits), both sides are off. The greater the pressure is outside the dead band, the greater the dc voltage to the airflow valve

motor. The voltage increases at the rate of 5.1 volts/.1 in. wg and saturates or reaches a maximum of about 25 volts when the pressure is 0.35 in. wg or more outside of the dead band.

e. The switching card also contains the low pressure alarm circuitry consisting basically of Q2, CR1, VR3, and the voltage divider resistors R8 and R25. This circuit is set to fire when the pressure falls below a preset level, 1.0 in. wg for the compartment control module and 0.33 in. wg for the protective entrance control module. When the pressure reaches the levels described above, the voltage across the four layer diode goes down to about 1 volt and allows base current to flow into the transistor Q2. The transistor is, therefore, "on" and provides a ground at terminal 9 of the switching card. In the system when this ground is provided, the MASK light/horn alarm or PE LOW PRESSURE light comes on. The circuit turns off when the voltage level of the low limit side falls within the proper limits.

f. The circuit consisting of R14, VR2, and Q4 is a series voltage regulator for the op amps and the pressure transducer. The circuit limits the voltage of these components to 28 vdc during high voltage transients.

1-11, LOSS OF POWER/PRESSURE WARNING SYSTEM.

a. The loss of power warning system provides an alarm, mask light and warning horn whenever the power switch on the compartment control module is turned on in the absence of input power to the compartment control module. An alarm is also provided when power is lost during normal operation.

b. When the compartment control module power switch is ON and the power is provided to the modular collective protection equipment, the batteries are charged through normal power distribution in the compartment control module through charging resistor R8. With the compartment control module power switch ON and a loss of power, battery power is provided to the loss of power warning system through terminals 5 and 6 of the compartment control module power switch of terminals 7 of A4 (printed circuit assembly switching auxiliary). Power is provided to the warning devices from terminal 8 of A4, Diodes A4 CR4 and CR5 prevent

power feedback into the rest of the 28 vdc power system, Diode CR3 provides power for the MASK indicator press-to-test. Diode A4 CR6 blocks power to the loss of power warning system when the system is off; however, press-to-test power is being provided through CR5.

c. During normal operation, 28 vdc power is provided through the closed contacts of pressure switch S6 and diode A4CR7 to keep A4Q3 turned off. Whenever there is a loss of pressure or a loss of power, 28 vdc is removed from the base of A4 Q3 and battery current provided by A4R5, A4VR1, and A4R7 turns A4Q3 on. Current provided by A4 Q3 and A4 R3 is directed to the base of A4 Q2 turning A4 Q2 on. When A4 Q2 is on, a ground is provided at terminals 1, 2, and 6 of A4 which activates the warning circuit.

d. Current will be supplied by A4 Q3 as long as the battery voltage is greater than 16 volts. In the range of 14-16 volts the transistor A4 Q3 will be turned off by A4 VR1 thus removing base drive for A4 Q2 and hence turning off the warning circuit and preventing deep discharge of the batteries.

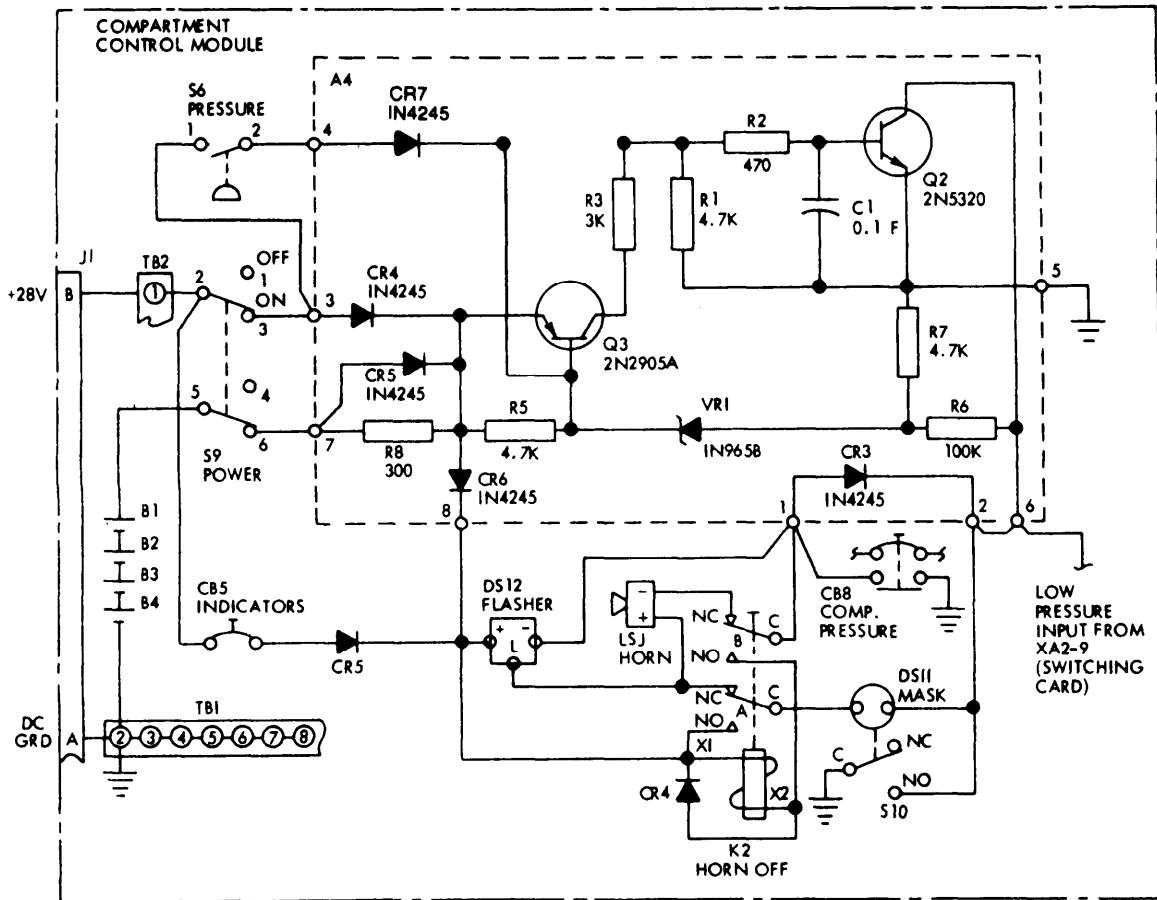

Loss of Power/Pressure Warning System Schematic Diagram

1-12. OVERALL SYSTEM. Refer to system schematic diagram below for component operation with other collective protection equipment.

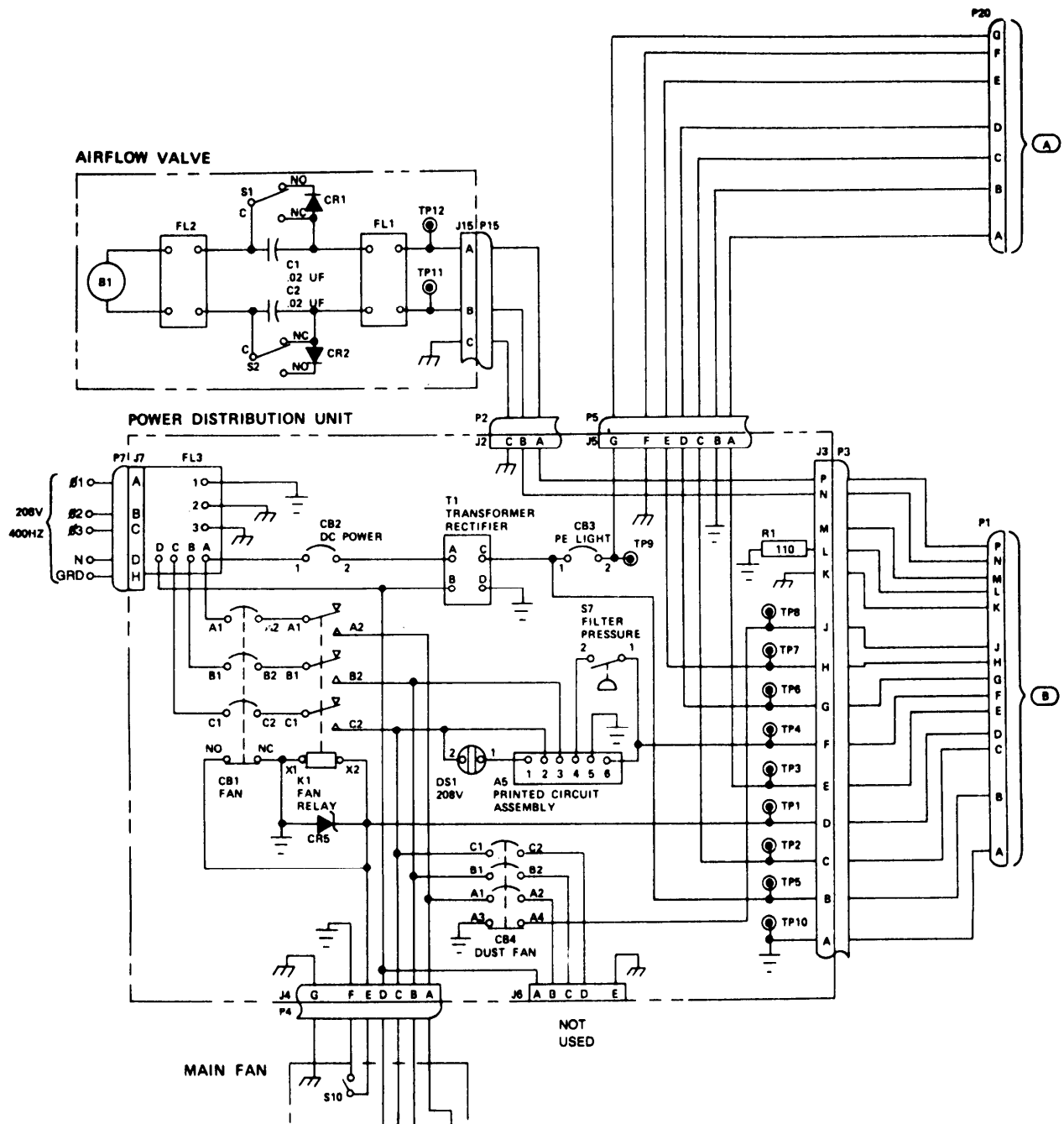

Collective Protection System Schematic Diagram

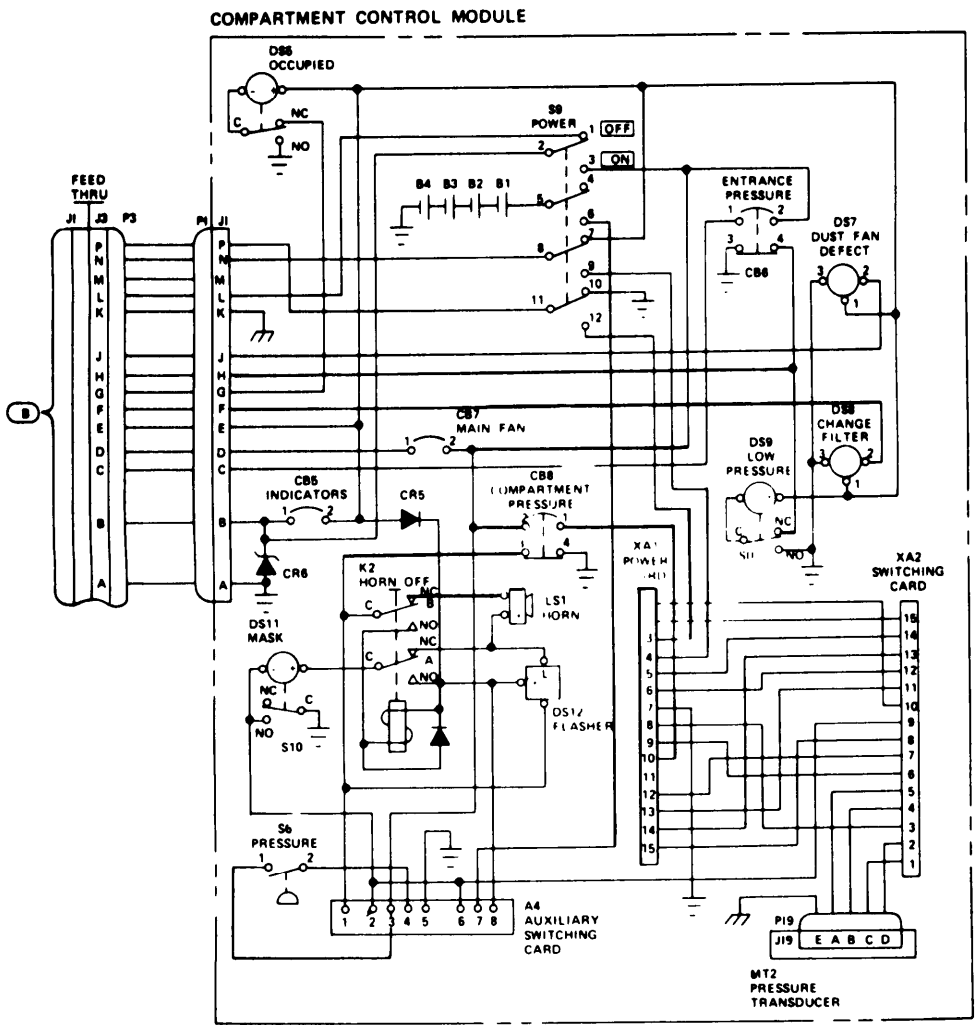
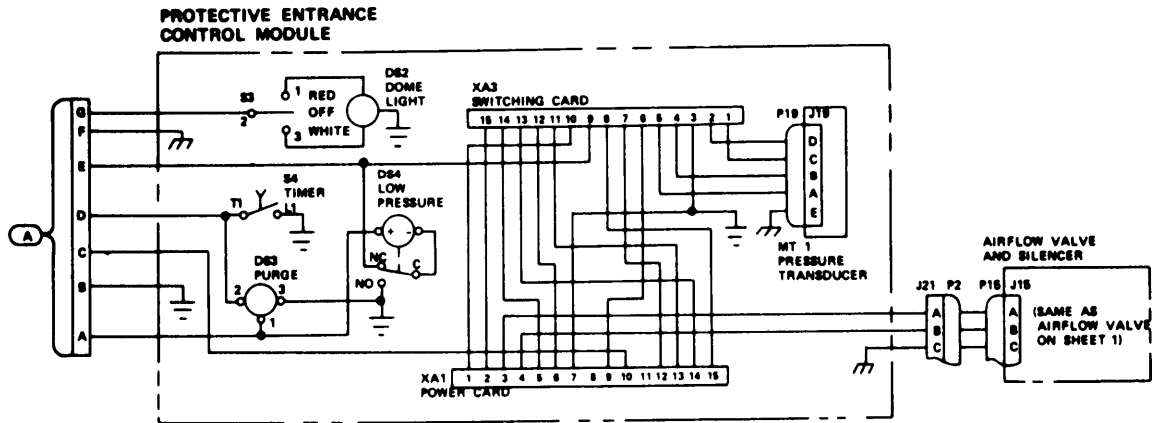

Collective Protection System Schematic Diagram (Sheet 2 of 2)