

**TECHNICAL MANUAL**

**ORGANIZATIONAL MAINTENANCE MANUAL  
RADAR INTERFACE EQUIPMENT MAINTENANCE**

**16K MEMORY  
VIDEO SIMULATOR UNIT**

**EXPANDED TROUBLESHOOTING  
LOGIC DIAGRAMS**

**GUIDED MISSILE AIR DEFENSE SYSTEM  
AN/TSQ-73**

---

**HEADQUARTERS, DEPARTMENT OF THE ARMY  
22 APRIL 1985**

TECHNICAL MANUAL }  
No. 9-1430-655-20-3-6 }

HEADQUARTERS  
DEPARTMENT OF THE ARMY  
Washington, D.C., 22 April 1985

**ORGANIZATIONAL MAINTENANCE MANUAL  
RADAR INTERFACE EQUIPMENT MAINTENANCE  
16K MEMORY, VIDEO SIMULATOR UNIT**

**EXPANDED TROUBLESHOOTING  
(LOGIC DIAGRAMS)**

**GUIDED MISSILE AIR DEFENSE SYSTEM  
AN/TSQ-73**

**REPORTING OF ERRORS**

You can help improve this publication. If you find any mistakes, or if you know of a way to improve the procedures, please let us know. Mail your letter or DA Form 2028-2, located in back of this manual direct to: Commander, U.S. Army Missile Command, ATTN: AMSMI-MMC-LE-A-P, Redstone Arsenal, AL 35898-5238. A reply will be furnished to you.

**TABLE OF CONTENTS**

<i>Chapter</i>		<i>Page</i>
5	LIST OF ILLUSTRATIONS.....	ii
	LIST OF TABLES.....	iii
	Section XVI. VIDEO PROCESSOR UNITS	
5-51	General.....	5-789
5-52	Logic Diagram.....	5-789
5-53	Using Logic Diagrams .....	5-789

LIST OF ILLUSTRATIONS

<i>Figure</i>	<i>Title</i>	<i>Page</i>
5-6	Single-Port 16K Memory Unit 1A1A1A7, Component Location .....	5-790
5-7	Video Simulator Unit 1A1A1A3, Component Location.....	5-792
FO-206	16K Memory Logic Diagram .....	
FO-207	VSU Azimuth Digitizer Logic Diagram .....	
FO-208	VSU Range Digitizer Logic Diagram .....	
FO-209	VSU Temporary Storage Register Logic Diagram.....	
FO-210	VSU Target Generator Load Recirculate Control Logic Diagram.....	
FO-211	VSU Target Generator Azimuth Compare Logic Diagram .....	
FO-212	VSU Target Generator Range Compare Logic Diagram.....	
FO-213	VSU Temporary Storage Register Logic Diagram.....	
FO-214	VSU Target Generator Beam Shaping and Hit/Miss Control Logic Diagram.....	
FO-215	VSU Target Generator Pulse Width Output Control Logic Diagram .....	
FO-216	VSU ECM and Chaff Generator Load Control and Analog Output Gating Logic Diagram .....	
FO-217	VSU ECM and Chaff Generator Azimuth Storage Logic Diagram .....	
FO-218	VSU ECM and Chaff Generator Azimuth Compare Logic Diagram .....	
FO-219	VSU Chaff Generator Feather Control Logic Diagram .....	
FO-220	VSU Chaff Generator Range Storage and Control Logic Diagram .....	
FO-221	VSU Chaff Generation Output Amplitude Control Logic Diagram.....	
FO-222	VSU ECM Generator Output Gating Control Logic Diagram .....	
FO-223	VSU ECM Generator Output Amplitude Control Logic Diagram .....	
FO-224	VSU Pseudo Random Sequence Generator Logic Diagram.....	
FO-225	VSU Receiver Noise Generator Logic Diagram .....	
FO-226	VSU Filter Control Logic Diagram.....	
FO-227	VSU Timing and Logic Grounds Diagram .....	
FO-228	VSU Digital-to-Analog Converter and Mixing Logic Diagram .....	
FO-229	VSU IFF Simulation Range Digitizer and Common Timing Logic Diagram .....	
FO-230	VSU IFF Simulation Azimuth Compare Logic Diagram .....	
FO-231	VSU IFF Simulation Range Compare Target I Logic Diagram .....	
FO-232	VSU IFF Simulation MOD N and MOD 16 Sweep Counter Target 1 Logic Diagram .....	
FO-233	VSU IFF Simulation MOD 16 Code Bit Counter Target 1 Logic Diagram .....	
FO-234	VSU IFF Simulation IFF Tag Generation Target I Logic Diagram .....	
FO-235	VSU IFF Simulation IFF Code Data and Hit/Miss Pattern Bits Target 1 Logic Diagram .....	
FO-236	VSU IFF Simulation Range Compare Target 2 Logic Diagram .....	
FO-237	VSU IFF Simulation MOD N and MOD 16 Sweep Counter Target 2 Logic Diagram .....	
FO-238	VSU IFF Simulation MOD 16 Code Bit Counter Target 2 Logic Diagram .....	
FO-239	VSU IFF Simulation IFF TAG Generation Target 2 Logic Diagram .....	
FO-240	VSU IFF Simulation IFF Code Data and Hit/Miss Pattern Bits Target 2 Logic Diagram .....	
FO-241	VSU IFF Simulation Range Compare Target 3 Logic Diagram .....	
FO-242	VSU IFF Simulation MOD N and MOD 16 Sweep Counter Target 3 Logic Diagram .....	
FO-243	VSU IFF Simulation MOD 16 Code Bit Counter Target 3 Logic Diagram .....	
FO-244	VSU IFF Simulation IFF Tag Generation Target 3 Logic Diagram .....	
FO-245	VSU IFF Simulation IFF Code Data and Hit/Miss Pattern Bits Target 3 Logic Diagram.....	

LIST OF ILLUSTRATIONS-Continued

<i>Figure</i>	<i>Title</i>	<i>Page</i>
FO-246	VSU IFF Simulation Range Compare Target 4 Logic Diagram .....	
FO-247	VSU IFF Simulation MOD N and MOD 16 Sweep Counter Target 4 Logic Diagram .....	
FO-248	VSU IFF Simulation MOD 16 Code Bit Counter Target 4 Logic Diagram .....	
FO-249	VSU IFF Simulation IFF Tag Generation Target 4 Logic Diagram .....	
FO-250	VSU IFF Simulation IFF Code Data and Hit/Miss Pattern Bits Target 4 Logic Diagram .....	
FO-251	VSU IOX Interface Data Receive Logic Diagram .....	
FO-252	VSU IOX Interface Data Receive Control Logic Diagram .....	
FO-253	VSU IOX Interface State Counter Logic Diagram .....	
FO-254	VSU IOX Interface Data Request Control Logic Diagram .....	
FO-255	VSU IOX Interface Parity Generator Logic Diagram .....	
FO-256	VSU IOX Interface Clock Generation Logic Diagram .....	
FO-257	VSU IOX Interface Command Storage Logic Diagram .....	
FO-258	VSU IOX Interface Reset, Indicator, and Range Azimuth Buffers Logic Diagram .....	
FO-259	VSU BITE Multiplexing and Storage Logic Diagram .....	
FO-260	VSU BITE Stroke Generators Logic Diagram .....	

LIST OF TABLES

<i>Tables</i>	<i>Title</i>	<i>Page</i>
5-40.1	Single-Port 16 K Memory Unit 1AIAA7, Circuit Card Location .....	5-791
5-41	Video Simulator Unit IAIA1A3, Circuit Card Location .....	5-793
5-42	Card Pin to Test Point Correlation .....	5-799

**Section XVI. 16K MEMORY AND VIDEO SIMULATOR UNIT**

**5-51. General.** This manual is Volume 6 of TM 9-1430-655-20-3, Radar Interface Equipment Maintenance for Guided Missile Air Defense System AN/TSQ-73. It contains the logic diagrams covering the single port 16K Memory and Video Simulator Unit for the use and guidance of advanced personnel responsible for repair of the RIE. Foldout 206 covers the 16K memory and foldouts 207 through 260 cover the VSU. The single port 16K memory unit is located in the center section of rack 1, 1A1A1, door B. The VSU is a single bay of circuit cards mounted in the front door of the lower rear section of rack 1, 1A1A1. Figure 5-6 illustrates the location of the 16K memory units and figure 5-7 illustrates the location of the VSU.

**5-52. Logic Diagram.** Logic diagrams provide the maintenance technician pin to pin signal flow, traceable by signal mnemonics, and I/O tables, to help identify faulty cards and to troubleshoot faults in the backplane

wiring and other areas that are beyond fault isolation capabilities of the MTS.

**5-53. Using Logic Diagrams.** The logic diagrams for the 16K memory provide circuit card pin to pin signal flow traceable within foldouts by signal mnemonics and between foldouts by signal mnemonics and alpha connectors. Table 5-40.1 contains the circuit card slot and the part number of the card. Signal flow for the VSU is traceable between circuit card pin numbers and is shown as inputs and outputs of integrated circuit logic devices on the circuit card. A specific signal can be followed between foldouts by using the signal mnemonic and the logic diagram input/output table. The circuit card slot is shown within the integrated circuit card device symbol. Table 5-41 contains the circuit slot and the part number of the card. Table 5-42 contains, by card part number, the test point for each of the 80 pins of MTS testable cards in the VSU.

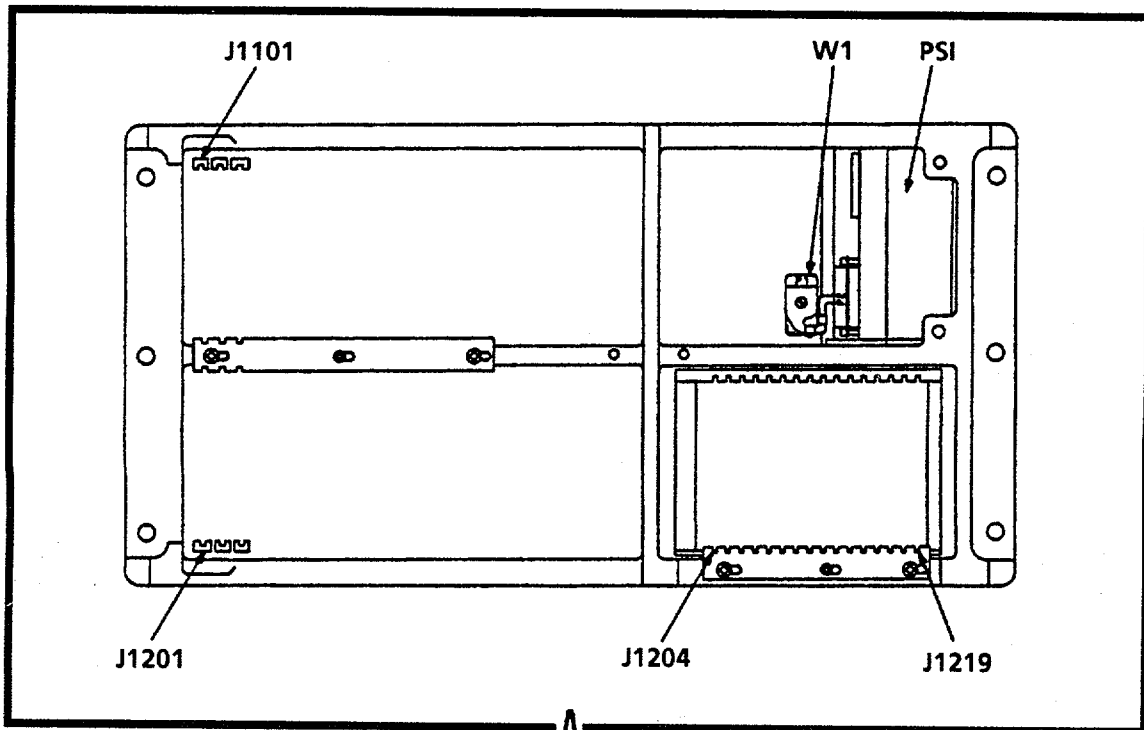
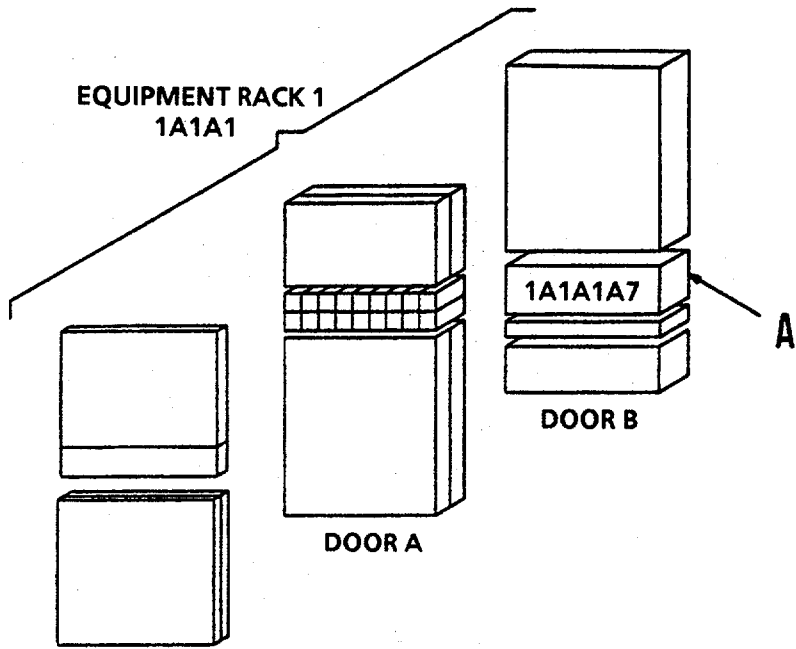

MS428086

Figure 5-6. Single-Port 16K Memory Unit 1A1A1A7, Component Location

Change 1 5-790

Table 5-40.1. Single-Port 16K Memory Unit 1A1A1A7, Circuit Card Location

Card slot	Part number	Card type	Color code			
			1	2	3	4
SHELF 1						
A1101	W386	Connector	-	-	-	-
A1101	W387	Connector	-	-	-	-
A1103	W540	Connector	-	-	-	-
SHELF 2						
A1201	W406	Connector	-	-	-	-
A1202	W407	Connector	-	-	-	-
A1203	W541	Connector	-	-	-	-
A1204	-	-	-	-	-	-
A1205	13143778	Timing and Control	-	-	-	-
A1206	13143777	CMOS Storage	-	-	Orange <sup>1</sup>	-
A1207	13143777	CMOS Storage	-	-	Orange <sup>1</sup>	-
A1208	13143777	CMOS Storage	-	-	Orange <sup>1</sup>	-
A1209	13143777	CMOS Storage	-	-	Orange <sup>1</sup>	-
A1210	13143777	CMOS Storage	-	-	Orange <sup>1</sup>	-
A1211	13143777	CMOS Storage	-	-	Orange <sup>1</sup>	-
A1212	13143777	CMOS Storage	-	-	Orange <sup>1</sup>	-
A1213	13143777	CMOS Storage	-	-	Orange <sup>1</sup>	-
A1214	13143777	CMOS Storage	-	-	Orange <sup>1</sup>	-
A1215	13143777	CMOS Storage	-	-	Orange <sup>1</sup>	-
A1216	13143777	CMOS Storage	-	-	Orange <sup>1</sup>	-
A1217	10283626	Quad NAND gate	Orange	Blue	Red	Blue
A1218	-	-	-	-	-	-
A1219	-	-	-	-	-	-

<sup>1</sup>13143777 cards have orange edge to identify CMOS devices; these cards are not testable by MTS and require special handling. Refer to CMOS cautionary notice on page a of this technical manual.

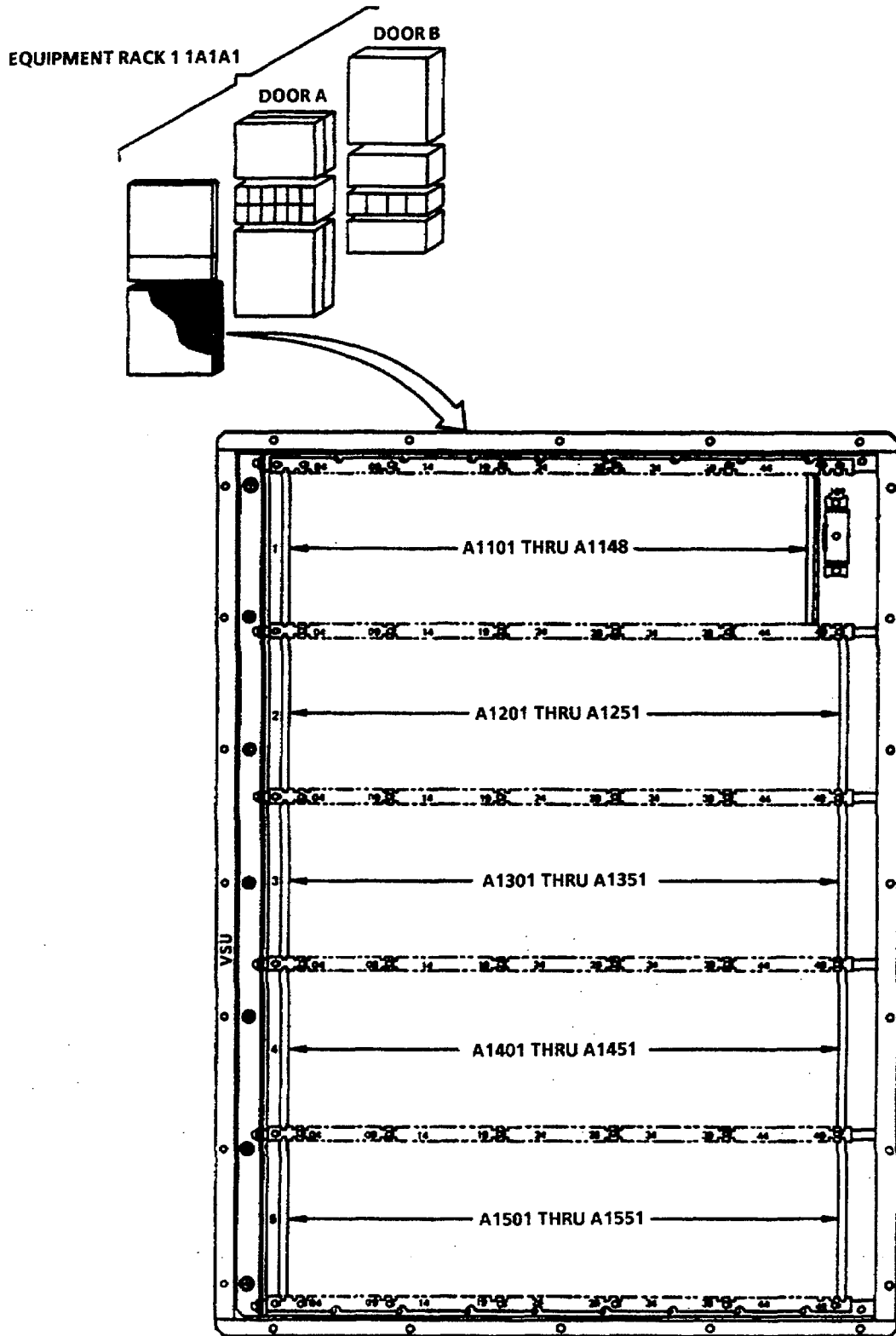

MS 197184

Figure 5-7. Video Simulator Unit 1A1A1A3, Component Location.

Change 1 5-792