

TECHNICAL MANUAL

**ORGANIZATIONAL- MAINTENANCE MANUAL
DATA DISPLAY GROUP
EQUIPMENT MAINTENANCE
EXPANDED TROUBLESHOOTING
(LOGIC DIAGRAMS)**

**GUIDED MISSILE
AIR DEFENSE SYSTEM
AN/TSQ-73**

HEADQUARTERS, DEPARTMENT OF THE ARMY

4 APRIL 1985

TECHNICAL MANUAL }
 NO. 9-1430-655-20-4-5 }

HEADQUARTERS
 DEPARTMENT OF THE ARMY
 Washington, D.C. 4 April 1985

**ORGANIZATION MAINTENANCE MANUAL: DISPLAY EQUIPMENT MAINTENANCE
 EXPANDED TROUBLESHOOTING (LOGIC DIAGRAMS)
 GUIDED MISSILE AIR DEFENSE SYSTEM AN/TSQ-73**

REPORTING ERRORS AND RECOMMENDING IMPROVEMENTS
 You can help improve this manual. If you find any mistakes, or if you know of a way to improve the procedures, please let us know. Mail your letter, DA Form 2028 (Recommended Changes to Publications and Blank Forms) or DA Form 2028-2, located in back of this manual, directly to: Commander, U.S. Army Missile Command, ATTN: AMSMI-LC-ME-P, Redstone Arsenal, AL 35898-5238. A reply will be furnished directly to you.

TABLE OF CONTENTS

Chapter	Page
LIST OF ILLUSTRATIONS	iii
LIST OF TABLES	iv
6 DISPLAY CONSOLE EXPANDED TROUBLESHOOTING	6-1
Section I. INTRODUCTION	
6-1. Scope	6-1
6-2. Expanded Troubleshooting Concept	6-1
6-3. Troubleshooting Aids	6-1
6-4. Physical Description	6-1
Section II. OVERALL THEORY OF OPERATION	
6-5. Overall Functional Description	6-9
6-6. Logic Theory Presentation	6-9
6-7. Circuit Card and Key Signal Lookup Tables	6-9
Section III. DETAILED DESCRIPTIONS	
6-8. Input Register Logic Detailed Description	6-104
6-9. Fault Status Byte Logic Detailed Description	6-104
6-10. Data Detection Logic Detailed Description	6-109
6-11. Input Pulse Detection Logic Detailed Description	6-109
6-12. Buffer Output Pulse Detection Logic Detailed Description	6-110
6-13. Detailed Description Parity Check and Loop/Interrupt Byte Logic	6-120

TABLE OF CONTENTS-Continued

	Page
Section III. DETAILED DESCRIPTIONS	
6-14. Input Counter Logic Detailed Description	6-120
6-15. State Gate Tree Logic Detailed Description	6-129
6-16. Refresh Memory-Entry Logic Detailed Description	6-130
6-17. Memory Storage Detailed Description	6-130
6-18. Memory 8-Way Multiplexer Detailed Description	6-140
6-19. Memory Output Multiplexer Detailed Description	6-140
6-20. Display Character Generator Detailed Description	6-140
6-21. Display Scan Register Detailed Description	6-140
6-22. Output Display 12-Way Clock Demultiplexer Detailed Description	6-140
6-23. Output Display Brightness Control Logic Detailed Description	6-152
6-24. FU Readout Register and Data Driver Detailed Description	6-152
6-25. Time-of-Day Logic Detailed Descriptions	6-157
6-26. Display Timing	6-162
6-27. LED Module Detailed Description	6-170
6-28. Clocking/Master Reset Detailed Description	6-170
Section IV. POWER DISTRIBUTION	
6-29. Data Display Group Power Distribution	6-186

LIST OF ILLUSTRATIONS

<i>Figure</i>	<i>Title</i>	<i>Page</i>
6-1.	Data Display Group (DDG)	6-2
6-2.	DDG Front Panel Assembly	6-3
6-3.	DDG Card Cage/Array Assembly	6-4
6-4.	DDG Cabinet Connector Cabling	6-5
6-5.	DDG Cable Set	6-6
6-6.	DDG Circuit Card Location	6-7
6-7.	Data Display Group Overall Block Diagram	6-10
6-8.	Input Register Block Diagram	6-105
6-9.	Fault/Status Byte Logic.....	6-107
6-10.	Data Detection Block Diagram	6-113
6-11.	Input Pulse Detection Block Diagram.....	6-115
6-12.	Input Pulse Detection Timing Diagram	6-119
6-13.	Output Pulse Detection Block Diagram	6-121
6-14.	Parity Check/Interrupt Byte Block Diagram	6-123
6-15.	Input Counter Block Diagram	6-127
6-16.	Simplified Block Diagram State Gate Tree.....	6-129
6-17.	State Gate Tree Block Diagram	6-131
6-18.	Memory Entry Block Diagram	6-141
6-19.	Memory Storage Block Diagram	6-149
6-20.	Memory 8 Way Multiplexer Block Diagram	6-151
6-21.	Memory 8-Way Multiplexer Timing Diagram.....	6-153
6-22.	Memory Output Multiplexer Block Diagram	6-155
6-23.	ROM Input/Output Scheme.....	6-157
6-24.	Display Character Generator Block Diagram	6-163
6-25.	Display Scan Register Functional Block Diagram	6-165
6-26.	Clock Demultiplexer Block Diagram	6-171
6-27.	Output Display Brightness Control Block Diagram	6-173
6-28.	FU Readout/Data Drivers Block Diagram.....	6-175
6-29.	Time-of-Day Logic Block Diagram	6-177
6-30.	Display Timing Block Diagram	6-179
6-31.	Display Timing Diagram	6-183
6-32.	MOD-27 Diagram	6-185
6-33.	LED Module	6-187
6-34.	LED Module Panel	6-189
6-35.	LED R/H and L/H Modules Block Diagram	6-191
6-36.	Clock and Master Reset Block Diagram	6-193
6-37.	Clock and Master Reset Timing Diagram	6-195
6-38.	Power Distribution Block Diagram	6-197
FO-1.	Input Register Logic Diagram	
FO-2.	Fault/Status Byte Logic Diagram	
FO-3.	Data Detection Logic Diagram	
FO-4.	Input Pulse Detection Logic Diagram	
FO-5.	Output Pulse Detection Logic Diagram	
FO-6.	Parity Check/Interrupt Byte Logic Diagram	
FO-7.	Input Counter Logic Diagram	
FO-8.	State Gate Tree Logic Diagram	
FO-9.	Memory Entry Logic Diagram	
FO-10.	Memory Storage Logic Diagram	
FO-11.	Memory 8-Way Multiplexer Logic Diagram	
FO-12.	Memory Output Multiplexer Logic Diagram	
FO-13.	Display Character Generator Logic Diagram	
FO-14.	Display Scan Register Logic Diagram	

LIST OF ILLUSTRATIONS
-Continued-

<i>Figure</i>	<i>Title</i>	<i>Page</i>
FO-15.	Clock Demultiplexer Logic Diagram	
FO-16.	Display Brightness Control Logic Diagram	
FO-17.	FU Readout Registers/Data Drivers Logic Diagram	
FO-18.	Time of Day Logic Diagram	
FO-19.	Display Timing Logic Diagram	
FO-20.	Pullups and Grounds Logic Diagram	
FO-21.	L/H LED Modules Logic Diagram	
FO-22.	R/H LED Modules Logic Diagram	
FO-23.	Clock/Master Reset Logic Diagram	
FO-24.	Control Panel Assembly.....	
FO-25.	Power Distribution Wiring Diagram	
FO-26.	DDG/IOX Interface Wiring Diagram	

LIST OF TABLES

<i>Table</i>	<i>Title</i>	<i>Page</i>
6-1.	Left-Hand Assembly Card Location Index	6-11
6-2.	Right-Hand Assembly Card Location Index	6-13
6-3.	Left-Hand Assembly Key Signal Lookup	6-16
6-4.	Right-Hand Assembly Key Signal Lookup	6-55
6-5.	Command Functions	6-104
6-6.	Fault and Indicator Status Bytes	6-111
6-7.	State Sequence	6-139
6-8.	ROM I/O Bit	6-158
6-9.	ASCII Character Code	6-158
6-10.	LED Bit Pattern	6-159
6-11.	Refresh Memory Organization	6-185

INPUTS	F/O - SH	OUTPUTS	F/O - SH	OUTPUTS	F/O - 2H
PBRALOV	8-1	PADDRO	4-0	PB031B	2-0
PCCG1AV	4-0				6-0
PCCG2AV	4-0	PBEDNAV	8-1	PB032B	2-0
PCCG3A	4-0	PBRAN0E	8-1		6-0
PGINDA	5-0	PBRAN1E	8-1		8-1
PGREQA	5-0	PBRAN2E	8-1	PB033B	2-0
PG60NA	6-0	PBRAN3E	8-1		6-0
PG61NA	6-0	PB0100E	8-1		8-1
PG62NA	6-0	PB0101E	8-1	PF01BR	3-0
PG63NA	6-0	PB0102E	8-1		4-0
PG64NA	6-0	PB0103E	8-2	PF02BR	3-0
PG65NA	6-0	PB012AV	8-1		4-0
PG66NA	6-0	PB013AV	8-1	PF03BR	3-0
PG67NA	6-0	PB020B	2-0	PF04BR	3-0
PG68NA	6-0			PF10BR	3-0
PG8MZ0	23-0			PF11BR	3-0
PJ010J	4-0	PB0200E	3-0	PF12BR	3-0
PJ017A	4-0	PB0201E	3-0	PF13BR	3-0
PJ0170	4-0	PB0202E	3-0	PF14BR	3-0
PK180B	10-0	PB0203E	3-0	PF15BR	3-0
PP0107T	8-1	PB021B	2-0	PF16BR	3-0
			6-0	PF17BR	3-0
		PB022B	2-0	PF18BR	3-0
			6-0	PK180P	3-0
		PB023B	8-1	PK180Q	6-0
			2-0	PR010T	4-0
		PB030B	6-0	PF020T	4-0
			6-0	PR110T	8-1
			8-1	PR180T	8-1
		PB0300E	3-0		
		PB0301E	3-0		
		PB0302E	3-0		
		PB0303E	3-0		

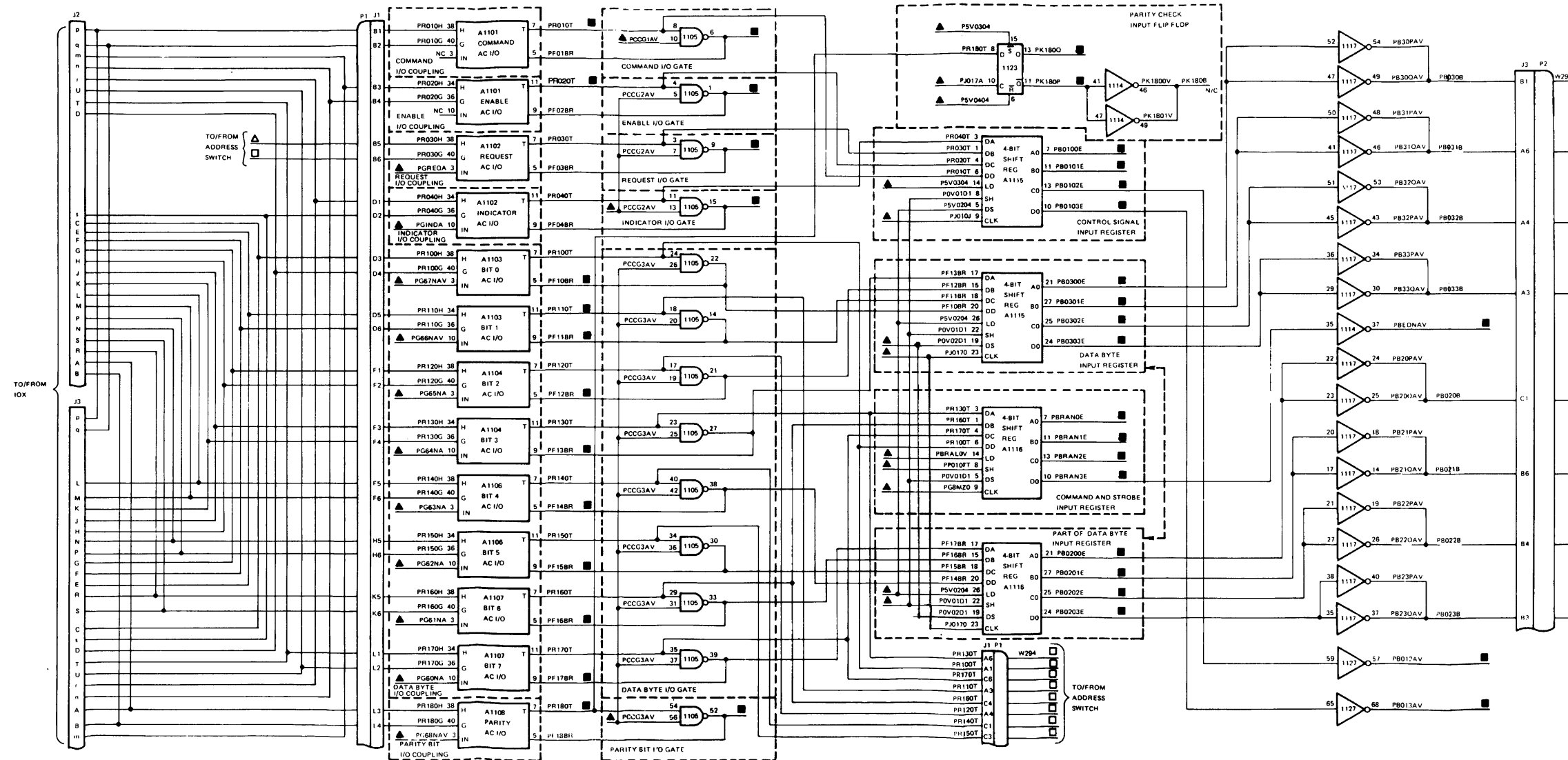

Change 1 FO-1. Input Register Logic Diagram (Sheet 1 of 2)

NOTES: UNLESS OTHERWISE SPECIFIED

- PARTIAL REFERENCE DESIGNATIONS ARE SHOWN; FOR COMPLETE DESIGNATIONS, PREFIX WITH APPLICABLE UNIT NUMBER AND ASSEMBLY DESIGNATION.
- ALL CIRCUITS SHOWN ON THIS FIGURE ARE CONTAINED ON RIGHT HAND CARD CAGE A3. (SINCE MULTIPLE DATA DISPLAY GROUPS ARE USED, ABBREVIATED DESIGNATIONS ARE SHOWN).
- DEFINITIONS FOR SYMBOLS SHOWN ARE AS FOLLOWS:
 - INPUT FROM ANOTHER FIGURE
 - INPUT FROM SAME FIGURE
 - OUTPUT TO ANOTHER FIGURE
 - OUTPUT TO BOTH SAME AND ANOTHER FIGURE
 - OUTPUT TO SAME FIGURE
- REFER TO TABLES 6-3 AND 6-4 FOR CIRCUIT CARD LOCATIONS.
- REFER TO TABLES 6-5 AND 6-6 FOR CIRCUIT CARD TEST POINTS.
- REFER TO DATA DISPLAY GROUP POWER DISTRIBUTION DIAGRAMS FOR DC POWER AND GROUND CIRCUITS.
- CIRCUIT SYMBOLS INCLUDE CARD LOCATION AND CIRCUIT PIN NUMBERS.