

**TECHNICAL MANUAL**

**ORGANIZATIONAL MAINTENANCE MANUAL  
MAGNETIC TAPE UNIT**

**EXPANDED TROUBLESHOOTING  
(LOGIC DIAGRAMS)**

**GUIDED MISSILE AIR DEFENSE SYSTEM  
AN/TSQ-73**

---

**HEADQUARTERS, DEPARTMENT OF THE ARMY**

**30 MAY 1984**

**ORGANIZATIONAL MAINTENANCE MANUAL: MAGNETIC TAPE UNIT  
 EXPANDED TROUBLESHOOTING  
 (LOGIC DIAGRAMS)**

**GUIDED MISSILE AIR DEFENSE SYSTEM AN/TSQ-73**

**REPORTING OF ERRORS**

You can help improve this publication. If you find any mistakes, or if you know of a way to improve the procedures, please let us know. Mail your letter, DA Form 2028 (Recommended Changes to Publications and Blank Forms), or DA Form 2028-2 located in back of this manual direct to: Commander, U.S. Army Missile Command, ATTN: AMSMI-LC-ME-P, Redstone Arsenal, AL 35898-5238. A reply will be furnished to you.

**TABLE OF CONTENTS**

Chapter	Page
LIST OF ILLUSTRATIONS.....	iii
LIST OF TABLES .....	v
 5                   MAGNETIC TEST SET EXPANDED TROUBLESHOOTING .....	 5-1
Section I. INTRODUCTION	
5-1. Scope .....	5-1
5-2. Expanded Troubleshooting Concept .....	5-1
5-3. Troubleshooting Aids .....	5-1
5-4. Physical Description .....	5-1
5-5. Circuit Card Location Index Tables and Key Signal Lookup Tables .....	5-4
Section II. OVERALL THEORY OF OPERATION	
5-6. Overall Functional Description .....	5-83
Section III. DETAILED DESCRIPTION	
5-7. General .....	5-84
5-8. Two-Phase Clock Generator .....	5-93
5-9. Main Timing Counter .....	5-94
5-10. Input/Output Interface .....	5-101
5-11. Input/Output Data Buffer .....	5-102
5-12. Read, Status, or Interrupt Output Logic .....	5-107
5-13. I/O Strobe and Request Counters .....	5-108
5-14. State and Byte Counters .....	5-116
5-15. Address, Command, and Enable Logic .....	5-116
5-16. MTU Commands Logic .....	5-124
5-17. Start/Stop Control Logic .....	5-130

TABLE OF CONTENTS - Continued

Chapter	Page
5-18. Write Timing Counter .....	5-146
5-19. Write Data Control Logic .....	5-151
5-20. Read Data Logic .....	5-164
5-21. Read Control Logic.....	5-164
5-22. Byte Timing Logic .....	5-170
5-23. Record Gap Detect Logic .....	5-176
5-24. End of Block (EOB) Counter .....	5-180
5-25. Error Detect Logic .....	5-182
5-26. Beginning of Tape/End of Tape (BOT/EOT) Detect Logic .....	5-196
5-27. Test Command Generator .....	5-198
5-28. MTT Control Logic .....	5-207
5-29. MTT Write Function Logic .....	5-212
5-30. MTT Read Function Logic .....	5-215
5-31. MTT Tape Drive Electronics .....	5-216
 Section IV. WIRING HARNESSES AND POWER DISTRIBUTION	
5-32. W2 Harness and Front Panel Wiring Diagram .....	5-222
5-33. MTT Wiring Diagram .....	5-222
5-34. W1, W3, and MTS Interface Wiring Diagram .....	5-222
5-35. Power Distribution .....	5-222

☆U.S. GOVERNMENT PRINTING OFFICE: 1991-531-038/40206

## LIST OF ILLUSTRATIONS

Figure	Title	Page
5-1.	MTU Major Subassemblies .....	5-2
5-2.	MTU Component Location .....	5-3
5-3.	MTU Cabling Diagram .....	5-5
5-4.	MTU Overall Block Diagram .....	5-85
5-5.	MTU Functional Block Diagram .....	5-87
5-6.	Two-Phase Clock Generator Block Diagram .....	5-95
5-7.	Main Timing Counter Block Diagram .....	5-97
5-8.	Main Timing Counter Timing Diagram .....	5-99
5-9.	Input/Output Interface Block Diagram .....	5-103
5-10.	Input/Output Data Buffer Block Diagram .....	5-105
5-11.	Read, Status, or Interrupt Output Logic Block Diagram .....	5-109
5-12.	I/O Strobe and Request Counters Block Diagram .....	5-111
5-13.	Request Counter Timing Diagram .....	5-113
5-14.	I/O Strobe Counter Timing Diagram .....	5-115
5-15.	State and Byte Counters Block Diagram .....	5-117
5-16.	State and Byte Counters Timing Diagram .....	5-119
5-17.	Address, Command, and Enable Logic Block Diagram .....	5-121
5-18.	I/O Data SYNC Flip-Flops Timing Diagram .....	5-125
5-19.	MTU Commands Logic Block Diagram .....	5-127
5-20.	Start/Stop Control Logic Block Diagram .....	5-131
5-21.	Look Ahead Delay Counter Timing Diagram .....	5-136
5-22.	DEV CMD SYNC Counter Timing Diagram .....	5-137
5-23.	Start Delay Counter Timing Diagram .....	5-139
5-24.	Stop Delay Counter Reset Timing Diagram .....	5-141
5-25.	Stop Delay Counter Timing Diagram .....	5-142
5-26.	Flying Start Delay Counter Timing Diagram .....	5-145
5-27.	Write Timing Counter Block Diagram .....	5-147
5-28.	Write Timing Counter Timing Diagram .....	5-149
5-29.	Write Data/Control Block Diagram .....	5-153
5-30.	Write/Erase Delay (65/80-xs) Timing Diagram .....	5-157
5-31.	Write Counter Timing Diagram .....	5-159
5-32.	Write Request Delay Counter Timing Diagram .....	5-161
5-33.	LRC Counter Timing Diagram .....	5-163
5-34.	Read Data Logic Block Diagram .....	5-165
5-35.	Read Control Logic Block Diagram .....	5-167
5-36.	Read Request Timing Diagram .....	5-171
5-37.	Read Byte Timing Logic Block Diagram .....	5-173
5-38.	Read Byte Counter Timing Diagram .....	5-175
5-39.	Record Gap Detect Logic Block Diagram .....	5-177
5-40.	Record Gap Detect Timing Diagram .....	5-179
5-41.	High Speed Gap Detect Timing Diagram .....	5-181
5-42.	EOB Counter Block Diagram .....	5-183
5-43.	EOB Counter Timing Diagram .....	5-185
5-44.	Error Detect Logic Block Diagram .....	5-187
5-45.	Longitudinal Redundancy Check Logic Block Diagram .....	5-191
5-46.	BOT/EOT Detect Logic Block Diagram .....	5-199
5-47.	BOT/EOT SYNC Counters Timing Diagram .....	5-201
5-48.	Test Command Generator Block Diagram .....	5-203
5-49.	Test Commands Timing Diagram .....	5-205
5-50.	MTT Control Logic Block Diagram .....	5-209
5-51.	MTT Write Function Block Diagram .....	5-213
5-52.	MTT Read Function Block Diagram .....	5-217
5-53.	MTT Tape Drive Electronics Block Diagram .....	5-219
5-54.	Power Distribution Block Diagram .....	5-223

LIST OF ILLUSTRATIONS - Continued

Figure	Title	Page
FO-1.	Two-Phase Clock Generator Logic Diagram .....	
FO-2.	Main Timing Counter Logic Diagram .....	
FO-3.	Input/Output Interface Logic Diagram .....	
FO-4.	Input/Output Data Buffer Logic Diagram .....	
FO-5.	Read, Status, or Interrupt Output Logic Diagram .....	
FO-6.	I/O Strobe and Request Counter Logic Diagram .....	
FO-7.	State and Byte Counters Logic Diagram .....	
FO-8.	Address, Command, and Enable Logic Diagram .....	
FO-9.	MTU Commands Logic Diagram .....	
FO-10.	Start/Stop Control Logic Diagram .....	
FO-11.	Write Timing Counter Logic Diagram .....	
FO-12.	Write Data/Control Logic Diagram .....	
FO-13.	Read Data Logic Diagram .....	
FO-14.	Read Control Logic Diagram .....	
FO-15.	Read Byte Timing Logic Diagram .....	
FO-16.	Record Gap Detect Logic Diagram .....	
FO-17.	End of Block Counter Logic Diagram .....	
FO-18.	Error Detect Logic Diagram .....	
FO-19.	BOT/EOT Detect Logic Diagram .....	
FO-20.	Test Command Generator Logic Diagram .....	
FO-21.	MTT Control Logic Diagram .....	
FO-22.	MTT Write Function Logic Diagram .....	
FO-23.	MTT Read Function Logic Diagram .....	
FO-24.	MTT Tape Drive Electronics Signal Flow Diagram .....	
FO-25.	W2 Harness and Front Panel Wiring Diagram .....	
FO-26.	MTT Wiring Diagram .....	
FO-27.	W1, W3, and Module Test Set (MTS) Interface Wiring Diagram .....	
FO-28.	MTU Power Distribution Diagram .....	
FO-29.	MTT Power Distribution Diagram .....	

LIST OF TABLES

Table	Title	Page
5-1.	Card Location in Logic Diagrams Index .....	5-6
5-2.	Key Signal Lookup Listing .....	5-12
5-3.	Timing Decoder Truth Table.....	5-176
5-4.	IRG Interrupt Decoder Truth Table .....	5-180
5-5.	I/O Parity Truth Table .....	5-195
5-6.	Set Error Register Inputs and Outputs .....	5-197
5-7.	Generated Byte Encoder Truth Table .....	5-208

v/(vi blank)

INPUT		OUTPUT	
SIGNAL	SOURCE FO-SH	SIGNAL	DESTINATION FO-SH
NONE		T16MHO	0600, 0700
		T16MIO	0600, 2000
		TXCP1B	1001, 1002, 1201, 1202, 1400
		TXCP3A	0200, 1100
		TXCP3B	0800, 0901, 1001, 1002, 1201, 1500, 1600, 1700, 1801, 1802, 1900
		TXCQ1B	0800, 0901, 0902, 1002, 1201, 1202, 1400, 1500, 1600, 1801, 1900
		TXCQ3B	0901, 0902, 1001, 1002, 1201, 1202, 1400, 1500, 1600, 1801, 1900
		TXGN1A	0500, 0600, 0800, 0901, 0902, 1400

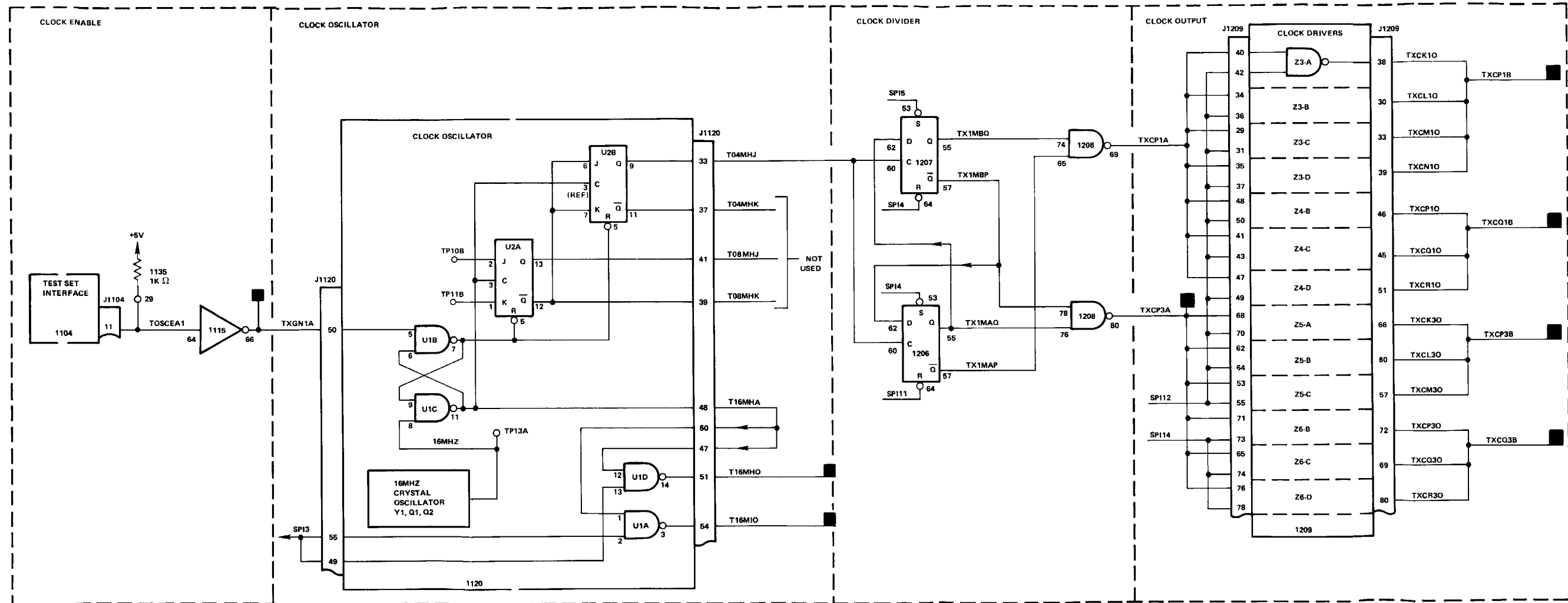

- NOTES: UNLESS OTHERWISE SPECIFIED
- PARTIAL REFERENCE DESIGNATIONS ARE SHOWN. FOR COMPLETE DESIGNATIONS, PREFIX WITH APPLICABLE UNIT NUMBER AND ASSEMBLY DESIGNATOR.
  - DEFINITIONS FOR SYMBOLS SHOWN ARE AS FOLLOWS:
    - ▲ INDICATES INPUT FROM ANOTHER FIGURE.
    - △ INDICATES INPUT FROM THE SAME FIGURE.
    - INDICATES OUTPUT TO ANOTHER FIGURE.
    - INDICATES OUTPUT TO THE SAME FIGURE.
    - ◻ INDICATES OUTPUT TO THE SAME AND ANOTHER FIGURE.
    - ↔ INDICATES BIDIRECTIONAL SIGNAL FLOW.
  - REFER TO TABLE 5-1 FOR CIRCUIT CARD LOCATION IN LOGIC DIAGRAMS INDEX.
  - REFER TO TABLE 5-2 FOR KEY SIGNAL LOOKUP LISTING.
  - REFER TO POWER DISTRIBUTION FOR DC POWER AND GROUND CIRCUITS.
  - CIRCUIT SYMBOLS INCLUDE CARD LOCATION AND CIRCUIT PIN NUMBERS.
  - TO DETERMINE CIRCUIT CARD PIN/TEST POINT PERFORM THE FOLLOWING:
    - A. FROM CIRCUIT SYMBOL NOTE CARD LOCATION AND CIRCUIT CARD PIN NUMBER
    - B. REFER TO APPROPRIATE TABLE IN TM 9-1430-655-20-5 FOR CARD PART NUMBER
    - C. REFER TO APPROPRIATE TABLE IN TM 9-1430-655-20-9 FOR CARD PIN/TEST POINT FOR MTS TESTABLE CARDS.

FO-1. Two-Phase Clock Generator Logic Diagram.