

TECHNICAL MANUAL

ORGANIZATIONAL MAINTENANCE MANUAL:

POWER CABINET EQUIPMENT MAINTENANCE

GUIDED MISSILE AIR DEFENSE SYSTEM AN/TSQ-73

This copy is a reprint which includes current pages from Changes 1 through 7.

HEADQUARTERS, DEPARTMENT OF THE ARMY

14 SEPTEMBER 1978

**ORGANIZATIONAL MAINTENANCE MANUAL:
POWER CABINET EQUIPMENT MAINTENANCE**

GUIDED MISSILE AIR DEFENSE SYSTEM AN/TSQ-73

TABLE OF CONTENTS

Chapter		Page
	LIST OF ILLUSTRATIONS	iii
	LIST OF TABLES	iii
1	INTRODUCTION.....	1-1
	Section I. GENERAL	1-1
	1-1. Scope.....	1-1
	1-2. Forms, Records, and Reports.....	1-1
	1-3. Destruction of Army Materiel to Prevent Enemy Use	1-1
	1-4. Reporting Equipment Publications Improvements.....	1-1
	1-5. References.....	1-1
	1-6. Abbreviations	1-1
	1-7. Official Nomenclature.....	1-1
	Section II. DESCRIPTION AND DATA.....	1-3
	1-8. General.....	1-3
	1-9. Physical	1-3
2	THEORY OF OPERATION	2-1
	Section I. OVERALL THEORY OF OPERATION	2-1
	2-1. General	2-1
	2-2. Functional Description.....	2-1
	Section II. DETAILED THEORY OF OPERATION	2-2
	2-3. General	2-2
	2-4. Power Transfer Unit A1	2-2
	2-5. AC/DC Conversion No. 1 Circuits.....	2-2
	2-6. AC/DC Conversion No. 2 Circuits.....	2-7
	2-7. AC/DC Converters PS1 and PS2.....	2-7
	2-8. DC Power Supply and Voltage Sensor Module PS3.....	2-9
	2-9. DC/AC Inverter PS4	2-9
	2-10. Emergency Power Supply	2-9
	2-11. Shelter Lighting Supplies.....	2-10
	2-12. Rack Temperature Sensor.....	2-11

TABLE OF CONTENTS-Continued

Chapter		Page
3	COMPONENT LOCATION, FAULT ISOLATION, AND TROUBLESHOOTING. ...	3-1
	Section I. GENERAL.....	3-1
	3-1. Scope.....	3-1
	3-2. Emergency Power Shutdown.....	3-1
	3-3. Normal Power Shutdown.....	3-1
	3-4. Tools and Test Equipment.....	3-1
	3-5. Preventive Maintenance Procedures.....	3-1
	3-6. Alinements and Adjustments.....	3-1
	Section II. COMPONENT LOCATION.....	3-2
	3-7. General.....	3-2
	3-8. Reference Designators.....	3-2
	3-9. Component Location.....	3-2
	Section III. FAULT ISOLATION AND TROUBLESHOOTING.....	3-10
	3-10. General.....	3-10
	3-11. Troubleshooting Aids.....	3-10
	3-12. Fault Isolation Flow Chart.....	3-10
4	REMOVAL AND REPLACEMENT AND CABLING/SCHEMATIC DIAGRAMS.....	4-1
	Section I. REMOVAL AND REPLACEMENT.....	4-1
	4-1. Scope.....	4-1
	4-2. Panel-Mounted Components, Removal and Replacement.....	4-1
	4-3. Power Cabinet Removal and Replacement.....	4-6
	4-4. Power Transfer Unit A1, Removal and Replacement.....	4-7
	4-5. Battery BT1 or BT2, Removal and Replacement.....	4-8
	4-6. AC/DC Converter PS1 or PS2, Removal and Replacement.....	4-9
	4-7. Power Distribution Circuit Card A2, Removal and Replacement.....	4-9
	4-8. Heat Sink Assembly, Removal and Replacement.....	4-10
	4-9. Electrical Filter Assembly, Removal and Replacement.....	4-10
	4-10. Power Transfer Unit Relay A1K1, Removal and Replacement.....	4-10
	4-11. Power Transfer Unit Surge Arresters A1E7 through A1E12, Removal and Replacement.....	4-10
	4-12. Power Transfer Unit Surge Arresters A1E13 through A1E16, Removal and Replacement.....	4-11
	4-13. Power Transfer Unit EMI Filters A1FL1 through A1FL3, Removal and Replacement.....	4-11
	Section II. CABLING/SCHEMATIC DIAGRAMS.....	4-12
	4-14. Power Cabinet Cabling and Schematic Diagrams.....	4-12
	4-15. Power Cabinet Interconnecting Cabling.....	4-12
	4-16. Power Cabinet Schematic Diagrams.....	4-12
Appendix		
A	LIST OF ABBREVIATIONS.....	A-1
INDEX	Index 1

LIST OF ILLUSTRATIONS

Figure	Title	Page
1-1.	Power Cabinet 1A2	1-2
1-2.	Power Cabinet, Major Components	1-4
1-3.	Power Demarkation Panel.....	1-6
2-1.	Power Transfer Unit A1, Functional Block Diagram	2-3
2-2.	Power Cabinet 1A2, Functional Block Diagram	2-5
2-3.	AC/DC Converter PSI and PS2, Functional Block Diagram	2-8
3-1.	Power Cabinet 1A2, Component Location	3-3
3-2.	AC Power Panel, Component Location.....	3-7
3-3.	DC Power Panel, Component Location	3-8
3-4.	Power Transfer Unit 1A2A1, Component Location.....	3-9
3-5.	Power Cabinet Fault Isolation Flow Chart.....	3-12
4-1.	Panel Indicator Lamp, Removal and Replacement.....	4-2
4-2.	Indicator Switch (Push-Button), Removal and Replacement.....	4-2
4-3.	Switch, Push-Button, Removal and Replacement.....	4-3
4-4.	Phase Indicator, Removal and Replacement.....	4-4
4-5.	Circuit Breaker (Toggle Type), Removal and Replacement	4-5
4-6.	Circuit Breaker (Magnetic Type), Removal and Replacement.....	4-6
4-7.	Switch Assembly, Removal and Replacement.....	4-7
4-8.	Power Cabinet, Interconnection Diagram	4-13
4-9.	Power Cabinet, Schematic Diagram	4-15
4-10.	Power Transfer Unit, Schematic Diagram.....	4-21

LIST OF TABLES

Table	Title	Page
1-1.	AN/TSQ-73 Official Nomenclatures.....	1-1
1-2.	Physical and Technical Characteristics.....	1-5
3-1.	Power Cabinet Reference Designators.....	3-2
3-2.	Flow Chart Symbology	3-11
3-3.	Power Cabinet Assembly Lamp Test Indications	3-27

CHAPTER 1 INTRODUCTION

Section I. GENERAL

1-1. Scope. This manual contains organizational maintenance information for the Guided Missile Air Defense System AN/TSQ-73 power cabinet (fig. 1-1). Chapter 1 provides power cabinet physical description and data. Chapter 2 describes the theory of operation. Chapter 3 provides maintenance instructions and fault isolation procedures and flow charts. Chapter 4 contains removal and replacement procedures.

1-2. Forms, Records, and Reports. Refer to DA PAM 738-750 for the use and completion of all forms required for operation and maintenance of the equipment.

1-3. Destruction of Army Materiel to Prevent Enemy Use. If capture of this equipment appears imminent, or if the equipment must be abandoned, it should be destroyed to prevent enemy use. Destruction procedures should be carried out only on orders from the cognizant authority. Refer to TM 43-0002-21 for procedures required for destruction of the equipment and related system materiel. Priority items requiring destruction are recorded tape transport cartridges and classified manuals.

1-4. Reporting Equipment Publications Improvements. Reporting of errors and omissions, and recommendations by the individual user for improving this publication is encouraged. Reports should be submitted on DA Form 2028, Recommended Changes to Publications, and forwarded to: Commander, U.S. Army Missile Command, ATTN: AMSMI-LC-ME-PMC, Redstone Arsenal, Alabama, 35898-5238.

1-5. References. Refer to List of Applicable Publications TM 9-1425-655-L for a list of related publications and reference documents.

1-6. Abbreviations. Refer to appendix A for a list of abbreviations used in this manual.

1-7. Official Nomenclature. The official nomenclature associated with the AN/TSQ-73 equipment is listed in table 1-1. In the table, a common name is also provided for each major unit.

Table 1-1. AN/TSQ-73 Official Nomenclature

Official nomenclature	Common name
Air Defense System, Guided Missile AN/TSQ-73(V)	AN/TSQ-73 system (battalion configuration) AN/TSQ-73 system (brigade configuration)
Shelter, Electrical Equipment S-529/TSQ-73(V)	System shelter (battalion configuration) System shelter (brigade configuration)
Console, Assault Fire Command, Guided Missile OJ-299/TSQ-73(V)	Display console
Data Display Group OD-96/TSQ-73(V)	Data display group (DDG)
Recorder-Reproducer, Guided Missile System, RD-449/TSQ-73(V)	Magnetic Tape Unit (MTU)
Test Set, Electronic Circuit Plug-In Unit TS-3317/TSQ-73(V)	Module test set (MTS)

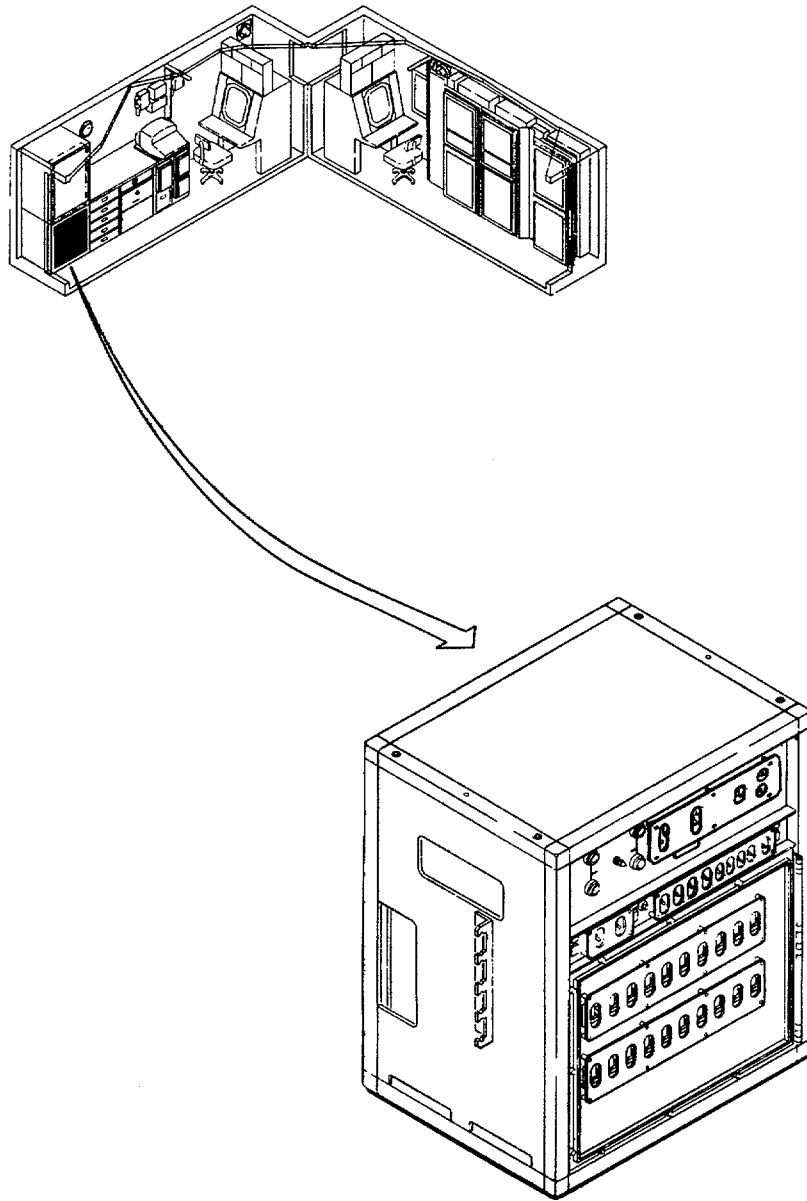

Figure 1-1. Power Cabinet 1A2

Section II. DESCRIPTION AND DATA

1-8. General. The power cabinet receives primary ac power from either a diesel engine generator or a motor generator and provides both ac and dc power for operating the AN/TSQ-73 system. The power cabinet contains controls and indicators for applying and monitoring primary power, and for supplying dc voltages from ac/dc power supplies or from emergency batteries.

1-9. Physical Description. The power cabinet (fig. 1-2) consists of an electrical cabinet assembly installed near the shelter entrance on the left side of the shelter below the voice communications central unit. The electrical cabinet assembly houses power transfer unit 1A2A1, ac and dc power panels, -135v battery 1A2BT1, +135v battery 1A2BT2, ac/dc converters JA2PS1 and 1A2PS2, dc power supply and voltage sensor module 1A2PS3, dc/ac inverter 1A2PS4, and 270v battery charger 1A2PS5. Table 1-2 lists the functional characteristics of the power cabinet.

a. *Power Transfer Unit 1A2A1.* The power transfer unit (PTU) is a chassis-mounted assembly installed in the upper portion of the power cabinet. The front panel contains controls and indicators for applying and selecting ac power sources. The PTU chassis (fig. 1-3) extends beyond the rear of the power cabinet and through an opening in the shelter wall for direct external access. A special RFI seal provides environmental and RFI shielding for the shelter interior. The rear panel of the PTU is designated the power demarkation panel and provides interconnection to the primary power sources, air conditioner, and the display junction box.

b. *AC and DC Power Panels.* The ac power panel is a fixed panel mounted below the PTU and contains front panel controls and indicators for applying ac power to internal circuits within the power cabinet and to internal shelter assemblies. The dc power panel is a hinged door assembly providing access to the power cabinet interior. The dc power panel contains circuit breakers that distribute dc power to the system.

c. *-135V Battery 1A2BT1 and +135V Battery 1A2BT2.* The batteries are mounted in the power cabinet and are accessible when the dc power panel is opened. Each battery consists of eight battery assembly modules. Each battery assembly module contains temperature sensors which provide a high temperature indication and high and low temperature protection. Each battery assembly module contains 14 individual nickel-cadmium battery cells connected in series. A high-temperature sensor provides a contact closure when the temperature inside the battery exceeds 149 (± 5.4) degrees F. High and low temperature protection is provided by temperature sensors which prevent the battery from charging when the temperature exceeds 149 (± 5.4) degrees F or falls below 39.2 (± 3.6) degrees F.

d. *AC/DC Converters 1A2PS1 and 1A2PS2.* The ac/dc converters are modular power supply assemblies mounted in the power cabinet adjacent to the batteries. Each ac/dc converter contains a conventional rectifier/ filter circuit for conversion of the externally supplied 3-phase, 4-wire, 400-Hz power input to +135v and -135v unregulated dc outputs. In addition, a power transformer and a circuit card assembly are contained in the ac/dc converter to supply low dc voltage for power monitoring and control circuits.

e. *DC Power Supply and Voltage Sensor Module 1A2PS3.* The dc power supply and voltage sensor module is a single modular assembly mounted on the left side of the power cabinet. The dc power supply converts 120 vac into a +5v output for driving indicator lamps and for fault signals from the power cabinet, voice communications central, and environmental control panel. The voltage sensor module provides sensing circuits for indicating overvoltage and undervoltage conditions in the power cabinet.

f. *DC/AC Inverter 1A2PS4.* The dc/ac inverter is a modular assembly mounted on the exhaust plenum on the right side of the power cabinet. The dc/ac inverter converts +135v input voltages to a 120v, 60 Hz output for driving the Keyboard Printer Unit (KPU) supplied with the system.

g. *270V Battery Charger 1A2PS5.* The battery charger is mounted on the rear of the power cabinet. The battery charger is a programmed current device capable of charging and maintaining the charge on two 135v batteries.

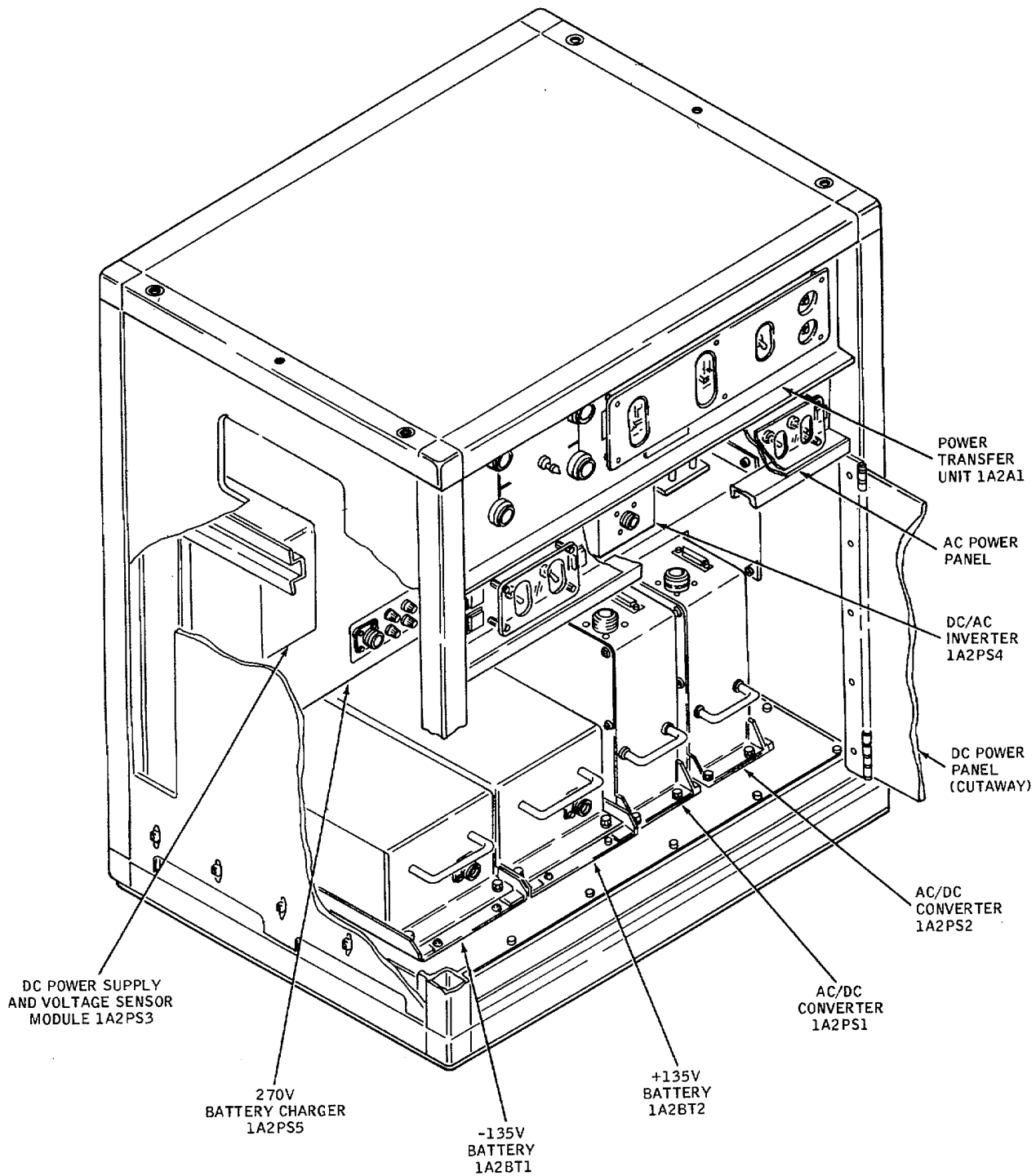

MS 196912

Figure 1-2. Power Cabinet, Major Components