

AVIATION UNIT AND AVIATION INTERMEDIATE
MAINTENANCE MANUAL WITH REPAIR PARTS AND
SPECIAL TOOLS LIST

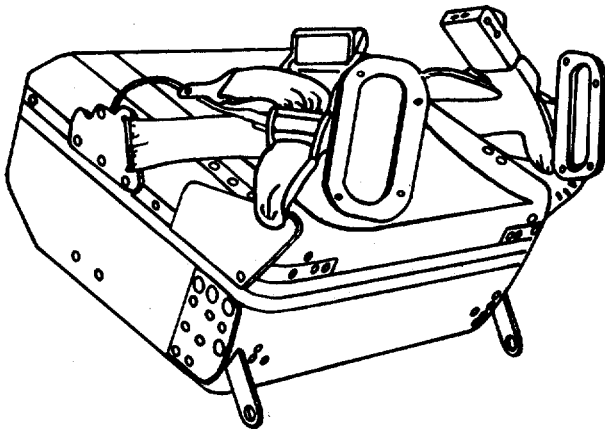
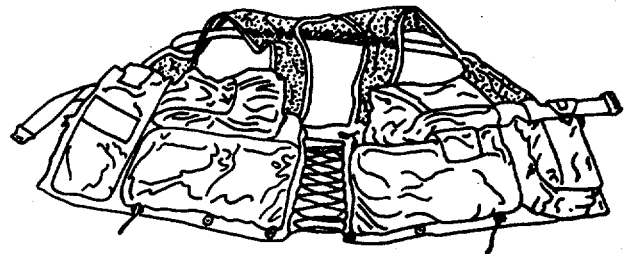
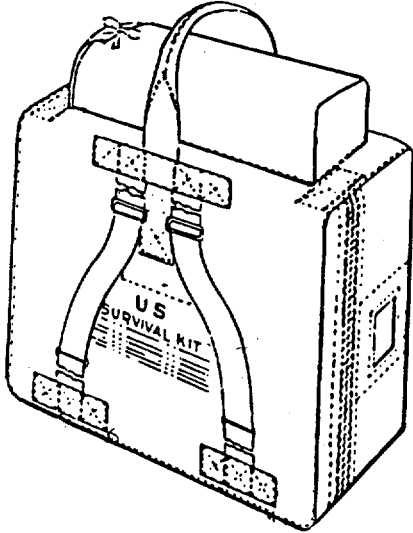

This copy is a reprint which includes current pages from Changes 1 through 7.

ARMY AIRCRAFT SURVIVAL KITS

"Approved for public release; distribution is unlimited."

*This manual supersedes TM55-1680-317-23&P, dated August 1975, including all changes.

TECHNICAL MANUAL

NO. 55-1680-317-23&P

HEADQUARTERS
DEPARTMENT OF THE ARMY
WASHINGTON, D.C., 26 March 1987

AVIATION UNIT AND AVIATION INTERMEDIATE MAINTENANCE MANUAL
with
Repair Parts and Special Tools List
for
ARMY AIRCRAFT SURVIVAL KITS

REPORTING ERRORS AND RECOMMENDING IMPROVEMENTS

You can improve this manual. If you find any mistakes, or if you know of a way to improve these procedures, please let us know. Mail your letter, DA Form 2028 (Recommended Changes to Publications and Blank Forms), or DA Form 2028-2 located in the back of this manual, directly to: Commander, US Army Aviation and Missile Command, ATTN: AMSAM-MMC-MA-NP, Redstone Arsenal, AL 35898-5000. A reply will be furnished to you. You may also provide DA 2028 information to AMCOM via e-mail, fax, or the World Wide Web. Our fax number is DSN 788-6546 or Commercial 256-842-6546. Our e-mail address is: 2028@redstone.army.mil. Instructions for sending an electronic 2028 may be found at the back of this manual immediately preceding the hard copy 2028. For the World Wide Web use: <http://amcom2028.redstone.army.mil>.

DISTRIBUTION STATEMENT A: Approved for public release; distribution is unlimited.

WARNING

OZONE DEPLETING CHEMICAL INFORMATION

This document has been reviewed for the presence of Class I Ozone Depleting Chemicals. As of the base through change 08, dated 1 April 1997, all references to Class I Ozone Depleting Chemicals have been removed from this document by substitution with Chemicals that do not cause atmospheric Ozone Depletion. Engineering, Environment, and Logistics Oversight Office.

HAZARDOUS MATERIAL INFORMATION

This document has been reviewed for the presence of solvents containing Hazardous Materials as defined by the EPCRA 302 and 313 lists. As of the base through change 08, dated 1 April 1997, all references to solvents containing Hazardous Materials have been removed from this document by substitution with Non-Hazardous or less Hazardous materials where possible. Engineering, Environment, and Logistics Oversight Office.

NOTE

The following Supply Catalogs have been superseded by the change: SC 1680-97-CL-A02, 29 Feb 80; SC 1680-97-CL-A03, 29 Feb 80; SC 1680-97-CL-08, 21 Aug 81; SC 1680-99-CL-A04, 20 Aug 74; and SC 8465-90-CL-P02, 29 Mar 85. All pertinent information has been incorporated.

TABLE OF CONTENTS

		Page
CHAPTER	1. INTRODUCTION	
Section	I. General Information	1-1
	II. Equipment Description	1-2
	III. Technical Principles of Operation	1-2
CHAPTER	2. MAINTENANCE INSTRUCTIONS	
Section	I. Service Upon Receipt of Material	2-1
	II. Preventive Maintenance Checks and Services (PMCS)	2-2
	III. General Repair Instructions	2-25
	IV. Specific Repair and Packing Instructions	2-36
	2-12. Individual Hot Climate Survival Kit	2-36
	2-13. Individual Cold Climate Survival Kit	2-51
	2-14. Individual Overwater Survival Kit	2-54
	2-15. SRU-21P Survival Vest - Kit	2-66
	2-16. OV-1 Aircraft Survival Vest	2-74
	2-17. Modification of Radio Pocket	2-76
	2-18. OV-1 Aircraft Rigid Seat Survival Kit (RSSK)	2-79
	2-19. Aircrew Survival Armor Recovery Vest, Insert, and Packets (SARVIP)	2-97
CHAPTER	3. A.L.S.E WORK, STORAGE AND FITTING AREAS	3-1
APPENDIX	A. Reference	A-1
	B. Maintenance Allocation Chart	B-1
	C. Repair Parts and Special Tools List	C-1

LIST OF ILLUSTRATIONS

Number	Title	Page
1-1.	The individual survival kit for all Army aircraft, except OV-1, typical.....	1-3
1-2.	The OV-1 aircraft individual survival kit	1-4
1-3.	The SRU-21/P survival vest, typical	1-5
1-4.	OV-1 aircraft (rigid seat survival kit) RSSK	1-5
1-4a.	Aircraft Survival Armor Recovery Vest, Insert, and Packets (SARVIP)	1-6
1-5.	Individual Survival Kit Components	1-12
2-1.	General patching details	2-27
2-2.	Installing an eyelet-type grommet, typical	2-32
2-3.	Seating a snap fastener, typical	2-33
2-4.	Knots used in survival kit maintenance	2-35
2-5.	The individual survival kit outer case, typical	2-36
2-6.	Kit outer case carrying handle construction details	2-38
2-7.	Individual survival kit (packed) (Sheet 1 of 3)	2-40
2-7.	Individual survival kit (packed) (Sheet 2 of 3)	2-41
2-7.	Individual survival kit (packed) (Sheet 3 of 3)	2-42
2-8.	Attaching strap replacement details, typical	2-44
2-9.	Strap assembly construction details, typical	2-45
2-9a.	Securing slide fastener thong.....	2-50

LIST OF ILLUSTRATIONS - Continued

Number	Title	Page
2-10.	Packing details for survival components of the individual hot climate survival kit	2-50.1
2-11.	Tarpaulin folding details	2-51
2-12.	Packing details for survival components of the individual cold climate survival kit	2-53
2-13.	Connector loop construction and attaching details	2-55
2-14.	Thong replacement details	2-57
2-15.	Ring chape construction details	2-58
2-16.	Ring chape installed on kit outer case slide interlocking fastener	2-58
2-17.	Connector web construction details	2-60
2-18.	Inner case packing details for survival components of the individual overwater survival kit	2-61
2-19.	One-man life raft packed in kit outer case upper section with connector web stowed	2-62
2-20.	Individual overwater survival kit packed and kit closure completed	2-63
2-21.	One-man life raft folding details	2-64
2-22.	Connecting the raft inflation assembly and kit closing details	2-65
2-23.	The SRU-21/P survival vest construction details	2-66
2-24.	Removing the SRU-21/P survival vest inside panel	2-70
2-25.	Assembly and stowage details for survival components of the SRU-21/P survival vest	2-72
2-26.	Radio with antenna stowed properly for SRU-21/P vest	2-73
2-27.	OV-1 aircraft individual survival vest components assembly and stowage details	2-75
2-27a.	Alternate method of attaching LPU-10 flotation equipment to the OV-1 survival vest	2-76
2-28.	SRU-31/P packet 1 and 2	2-77
2-29.	Radio pocket flap alterations for OV-1 vest	2-78
2-30.	Radio with antenna stowed properly in OV-1 vest	2-78.1
2-31.	OV-1 aircraft rigid seat survival kit with seat pad and thigh support pads	2-79
2-32.	RSSK 1 man life raft folding details	2-80
2-33.	Attaching dropline around neck of valve	2-82
2-34.	Passing actuating line through pull-cable loop	2-82
2-34a.	Raft retaining line OV-1 RSSK	2-82.1
2-35.	OV-1 aircraft RSSK, equipment bag, and drop line (Sheet 1 of 3)	2-84
2-35.	OV-1 aircraft RSSK, equipment bag, and drop line (Sheet 2 of 3)	2-85
2-35.	OV-1 aircraft RSSK, equipment bag, and drop line (Sheet 3 of 3)	2-86
2-36.	OV-1 aircraft rigid seat survival kit with harness assembly (Sheet 1 of 3)	2-87
2-36.	OV-1 aircraft rigid seat survival kit with harness assembly (Sheet 2 of 3)	2-88
2-36.	OV-1 aircraft rigid seat survival kit with harness assembly (Sheet 3 of 3)	2-89
2-37.	OV-1 aircraft RSSK canopy release and quick release handle	2-91
2-38.	OV-1 aircraft RSSK stiffener and housing latch assembly	2-92
2-39.	Packing details for survival components of the OV-1 aircraft RSSK hot climate survival kit	2-94
2-40.	Packing details for survival components of the OV-1 aircraft RSSK cold climate survival kit	2-95
2-41.	Packing details for survival components of the OV-1 aircraft RSSK overwater survival kit	2-96
2-42.	SARVIP	2-97
2-43.	Assembly of SARVIP components	2-103
C-1.	Survival kit, individual, hot climate	C-6
C-2.	Survival kit, individual, cold climate	C-8
C-3.	Survival kit, individual, overwater	C-10
C-4.	Rigid seat survival kit, hot climate	C-12
C-5.	Rigid seat survival kit, cold climate	C-14
C-6.	Rigid seat survival kit, overwater	C-16
C-7.	Individual survival kit vest-type SRU-21/P	C-18
C-8.	Individual survival kit vest - OV-1 aircraft	C-20
C-9.	Rigid seat survival kit	C-22
C-10.	Survival kit lid assembly	C-24
C-11.	SARVIP	C-25.1

CHAPTER 1

INTRODUCTION

Section 1. GENERAL INFORMATION

1-1. SCOPE

- a. Type of Manual Aviation Unit and Aviation Intermediate Maintenance Manual (including Repair Parts and Special Tools List)
- b. Model Number and Equipment Name Army Aircraft Survival Kits
- c. Purpose of Equipment Used to aid flying personnel in survival situations.

1-2. MAINTENANCE FORMS, RECORDS AND REPORTS

- a. Maintenance forms and records used by Army personnel are prescribed by DA PAM 738-751.

1-3. DESTRUCTION OF ARMY MATERIAL TO PREVENT ENEMY USE

- a. Authority. The equipment will be destroyed if it is in danger of being captured and used by the enemy. Refer to TM 750-244-1-2.

1-4. REPORTING OF EQUIPMENT IMPROVEMENT RECOMMENDATIONS (EIR)

If your survival equipment needs improvement, let us know. Send us an EIR. You, the user, are the only one who can tell us what you don't like about your equipment. Let us know why you don't like the design or performance.

- a. Army-EIR will be prepared using DA Form 2407, Maintenance Request. Instructions for preparing EIRs are provided in DA PAM 738-751. Functional users manual for the Army Maintenance Management System Aviation (TAMMS-A). EIRs should be mailed directly to Commander, U. S. Army Aviation and Missile Command, ATTN: AMSAM-MMC-MA-NP, Redstone Arsenal, AL. 35898-5230. A reply will be furnished directly to you.

Section II. EQUIPMENT DESCRIPTION

1-5. EQUIPMENT CHARACTERISTICS, CAPABILITIES, AND FEATURES

- * Completely self-contained.
- * Provides downed aircrew member with essential items needed in survival situations.
- * Lightweight and portable for transporting to other locations.
- * Provides a means of communication to downed aircrewmembers.

1-6. LOCATION OF MAJOR COMPONENTS

For location of major components see the following sections describing the various kits.

1-7. EQUIPMENT DATA

The kits are as light and compact as possible, and are carried aboard all Army aircraft and are easily transported in emergency situations. Any item used for training will not be used for service in any survival kit, and shall be marked, "For Training Only".

Section III. TECHNICAL PRINCIPLES OF OPERATION

1-8. EQUIPMENT DESCRIPTION

- a. The Individual Hot Climate, Cold Climate, and Overwater Survival Kits. The individual hot climate, cold climate, and overwater survival kits (figure 1-1) are complete survival packages which are carried aboard all Army aircraft, except OV-1 aircraft, according to the survival environment along the routes of flight. Components of each of the survival kits are contained within a canvas or nylon case which is equipped with a web carrying handle and two parachute attaching straps. The straps permit the applicable kit to be connected to an emergency-type personnel parachute harness in the event of emergency bailout during flight. The contents of each individual survival kit shall vary according to the kit type as outlined in chapter 2. However, of the three kit types, the overwater kit is the only kit which contains one-man life raft and a carbon dioxide cylinder for raft inflation.

NOTE

For economic reasons, hot/cold climate survival kits may be converted from one configuration to another by adding or subtracting the appropriate components required. (Fig. 1-5) when hot/ cold climate survival kits are converted, place tape, NSN 7510-00-266-5006, over hot/cold identification. Using a black marker, write the appropriate configuration on the tape.

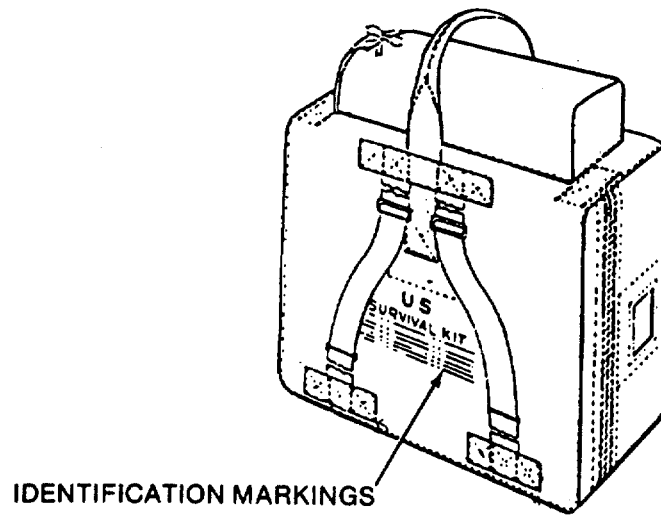

Figure 1-1. The individual survival kit for all Army aircraft, except OV-1, typical

1.8. EQUIPMENT DESCRIPTION - Continued

- b. The OV-1 Aircraft Rigid Seat Survival Kits (RSSK). The rigid seat survival kits are similar to those * described above, except that kit container is made of rigid fiberglass. The rigid seat survival kit (RSSK) also includes a retention assembly for the seat occupant. The survival kit assembly fits in the seat pan and is secured by two lower attachment lugs, which are released only when the time release mechanism or the manual override handle is actuated. An occupant retention assembly is attached to both sides of the survival container and clips to a floating lap belt which is attached to the personnel harness. To gain access to an equipment bag containing the survival gear, squeeze and pull the special grip handles to release the assembly which locks the container bottom to the lid assembly. Use only a normal handshake to squeeze. Pull until the small steel ball is visible. The seat pan provides the occupant with proper support for the lower portion of the torso and consists of a seat cushion and a rigid seat survival kit.

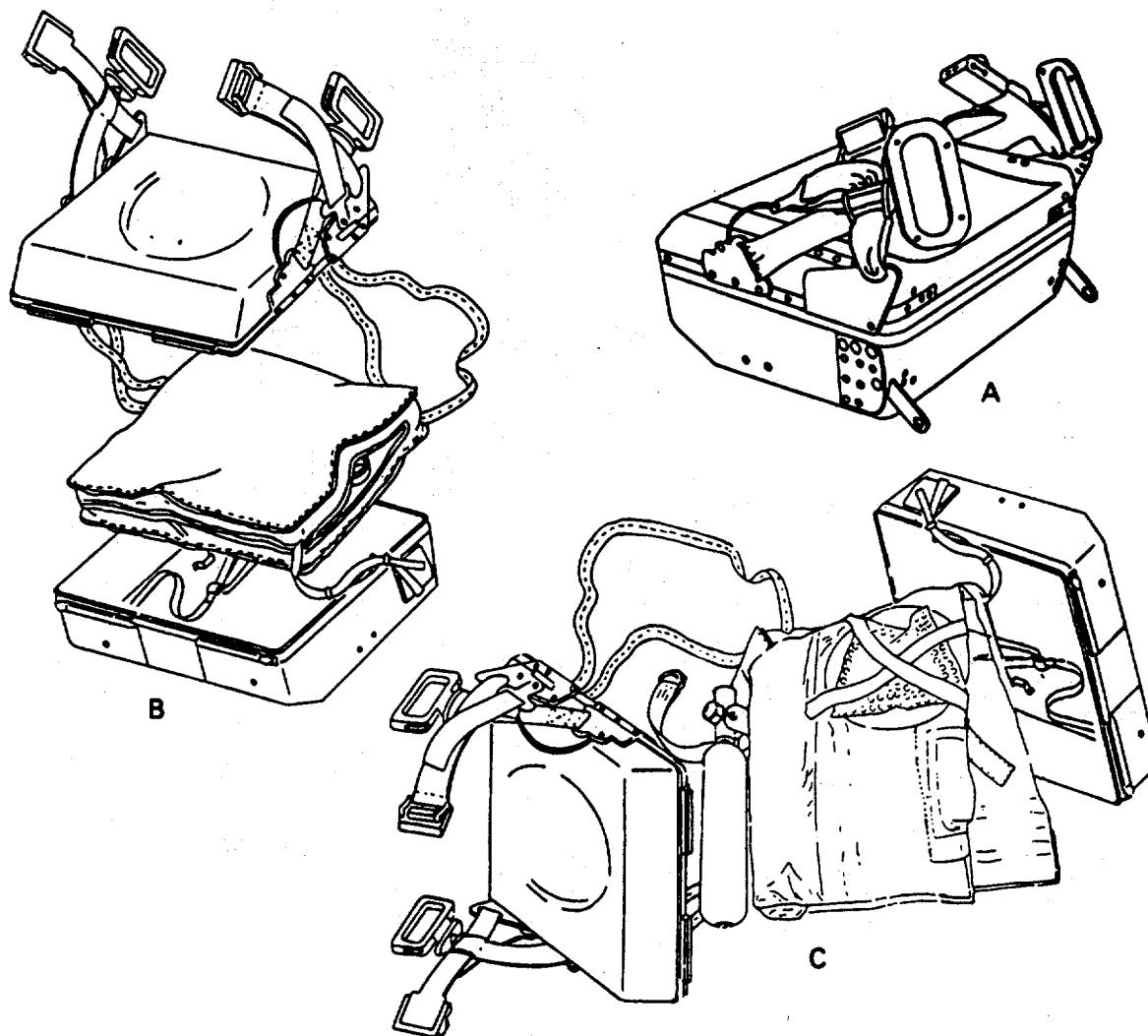

Figure 1-2. OV-1 Aircraft Individual Survival Kit.
 A. Rigid Seat Survival Kit (RSSK) Seat Container
 B. The Hot or Cold Climate Kit, Typical
 C. The Overwater Kit