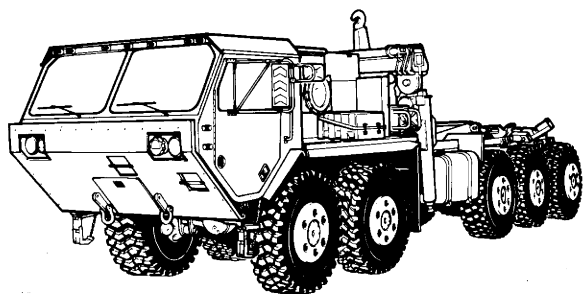


# TM 9-2320-364-10

THIS MANUAL SUPERSEDES TM 9-2320-364-10 DATED 25 FEB 1994, INCLUDING ALL CHANGES.

## OPERATOR'S MANUAL



**TRUCK, TRACTOR, M1074  
AND M1075 PALLETIZED  
LOAD SYSTEM (PLS)  
NSN 2320-01-304-2277  
NSN 2320-01-304-2278**

HOW TO USE THIS MANUAL	iii
EQUIPMENT DESCRIPTION	1-9
OPERATOR'S CONTROLS AND INDICATORS	2-3
PREVENTIVE MAINTENANCE CHECKS AND SERVICES	2-55
OPERATION UNDER USUAL CONDITIONS	2-153
OPERATION UNDER UNUSUAL CONDITIONS	2-673
TROUBLESHOOTING	3-1
MAINTENANCE PROCEDURES	3-45
BASIC ISSUE ITEMS LIST	B-1
INDEX	INDEX-1

### DISTRIBUTION RESTRICTION

Approved for public release; distribution is unlimited.

**HEADQUARTERS, DEPARTMENT OF THE ARMY**

**AUGUST 1999**

# TRUCK, TRACTOR, M1074 and M1075 PALLETIZED LOADING SYSTEM (PLS) (NSN 2320-01-304-2277) (NSN 2320-01-304-2278)

Current as of 01 August 1999

## REPORTING ERRORS AND RECOMMENDING IMPROVEMENTS

You can help improve this publication. If you find any mistakes or if you know of a way to improve the procedures, please let us know. Submit your DA Form 2028 (Recommended Changes to Publications and Blank Forms), through the Internet, on the Army Electronic Product Support (AEPS) website. The Internet address is <http://aeps.ria.army.mil>. If you need a password, scroll down and click on "ACCESS REQUEST FORM." The DA Form 2028 is located in the ONLINE FORMS PROCESSING section of the AEPS. Fill out the form and click on SUBMIT. Using this form on the AEPS will enable us to respond quicker to your comments and better manage the DA Form 2028 program. You may also mail, fax or email your letter, DA Form 2028, or DA Form 2028-2, located at the back of this manual direct to: Commander, U.S. Army Tank-automotive and Armaments Command, ATTN: AMSTA-AC-NML, Rock Island, IL 61299-7630. The email address is [amsta-ac-nml@ria.army.mil](mailto:amsta-ac-nml@ria.army.mil). The fax number is DSN 793-0726 or Commercial (309) 782-0726. A reply will be furnished to you.

## TABLE OF CONTENTS

CHAPTER 1	INTRODUCTION .....	1-1
Section I	General Information .....	1-1
Section II	Equipment Description .....	1-9
Section III	Principles of Operation .....	1-27
CHAPTER 2	OPERATING INSTRUCTIONS .....	2-1
Section I	Descriptions and Use of Operator's Controls and Indicators .....	2-3
Section II	Preventive Maintenance Checks and Services (PMCS) .....	2-53
Section III	Operation Under Usual Conditions .....	2-153
Section IV	Operation Under Unusual Conditions .....	2-672

\* This manual supersedes TM 9-2320-364-10, 25 February 1994.

## TABLE OF CONTENTS – (Cont.)

CHAPTER 3	MAINTENANCE INSTRUCTIONS .....	3-1
Section I	Lubrication Instructions .....	3-1
Section II	Troubleshooting Procedures .....	3-1
Section III	Maintenance Procedures .....	3-45
APPENDIX A	REFERENCES .....	A-1
APPENDIX B	BASIC ISSUE ITEMS (BII) LISTS .....	B-1
APPENDIX C	ADDITIONAL AUTHORIZATION LIST (AAL) .....	C-1
APPENDIX D	EXPENDABLE AND DURABLE SUPPLIES AND MATERIALS LIST .....	D-1
APPENDIX E	STOWAGE AND SIGN GUIDE (FOR COEI, BII, AND APPLICABLE AAL ITEMS) .....	E-1
APPENDIX F	ON-TRUCK EQUIPMENT LOADING PLAN .....	F-1
APPENDIX G	LUBRICATION INSTRUCTIONS .....	G-1

## HOW TO USE THIS MANUAL

This manual is designed to help operate and maintain the Model M1074 and M1075 Tractor Truck, NSN 2320-01-304-2277 and 2320-01-304-2278. Listed below are some of the features included in this manual to help locate and use the needed information:

- A front cover Table of Contents is provided for quick reference to chapters and sections that will be used often.
- Warning, caution and note headings, subject headings and other essential information are printed in bold type making them easier to see.
- In addition to text, there are exploded-view illustrations showing how to take a component off and put it back on. Cleaning and inspection criteria are also included where necessary.
- Chapter 1 of this manual describes the PLS and provides equipment data.
- Chapter 2 of this manual covers Operator's Controls and Indicators, Preventive Maintenance and Operating Instructions.
- Chapter 3 of this manual covers instructions for Troubleshooting and Unscheduled Maintenance.
- Appendix A covers the References used in this manual.
- Appendix B covers the Components of End Item (COEI) and Basic Issue Items (BII) Lists.
- Appendix C covers the Additional Authorized List (AAL) of items authorized for the PLS.
- Appendix D covers the Expendable and Durable Items List for the PLS.
- Appendix E covers the stowage and sign guide for the PLS.
- Appendix F covers the On-Truck equipment loading plan for the PLS.
- Appendix G covers the Operator's Lubrication requirements for the PLS.
- An Alphabetical Index is provided to help locate items in the text.

Follow these guidelines when using this manual:

- The operator must read through this manual and become familiar with the contents before attempting to operate the PLS.
- Read all WARNINGS and CAUTIONS before performing any procedure.

# CHAPTER 1

## INTRODUCTION

Para	Contents	Page
1-1	Scope .....	1-1
1-2	Maintenance Forms and Records .....	1-2
1-3	Corrosion Prevention and Control (CPC) .....	1-2
1-4	Destruction of Army Materiel to Prevent Enemy Use .....	1-2
1-5	Reporting Equipment Improvement Recommendations (EIR) .....	1-7
1-6	Warranty Information .....	1-7
1-7	Nomenclature Cross-Reference List .....	1-7
1-8	List of Abbreviations .....	1-7
1-9	Equipment Characteristics, Capabilities and Features .....	1-9
1-10	Location and Description of Major Components .....	1-12
1-11	Equipment Data .....	1-14
1-12	Systems Introduction .....	1-27
1-13	Electrical System .....	1-27
1-14	Engine and Drivetrain .....	1-28
1-15	Hydraulic System .....	1-29
1-16	Air System .....	1-29
1-17	Cooling System .....	1-32
1-18	Fuel System .....	1-33
1-19	Material Handling Crane (MHC) .....	1-34
1-20	Container Handling Unit (CHU) .....	1-36
1-21	Flatrack (FR) .....	1-38
1-22	Palletized Load System Trailer (PLST) .....	1-39
1-23	Load Handling System (LHS) .....	1-39
1-24	Self-Recovery Winch Kit (SRW) .....	1-40

### Section I. GENERAL INFORMATION

#### 1-1. SCOPE.

This manual is provided to maximize use of the Palletized Load System (PLS) by presenting operation and operator performed maintenance instructions. Read these instructions thoroughly before operating the truck. This manual is used for operation of the Palletized Load System M1074 and M1075 series, hereafter called the truck, and associated equipment. M1074 series trucks are similar to M1075 except for the addition of a Material Handling Crane (MHC), and Self-Recovery Winch (SRW) Kit. Models are listed on page 1-2.

**1-1. SCOPE (CONT).**

<b>MODEL</b>	<b>DESCRIPTION</b>
<b>M1074</b>	Cargo truck equipped with a Load Handling System (LHS) capable of self-loading and unloading. The truck is also equipped with a Material Handling Crane (MHC). See Figure 1-1.
<b>M1075</b>	Cargo truck equipped with a Load Handling System (LHS) capable of self-loading and unloading. See Figure 1-2.
<b>M1076</b>	Palletized Load System Trailer (PLST) is designed specifically for Palletized Load System. The trailer can be loaded directly from the truck using the Load Handling System (LHS) and Flatrack M1077. See Figure 1-3.
<b>M1077</b>	The flatrack is designed specifically for use with the Palletized Load System (PLS). The flatrack is used as a movable cargo bed for the truck and Palletized Load System Trailer (PLST). See Figure 1-4.

**1-2. MAINTENANCE FORMS AND RECORDS.**

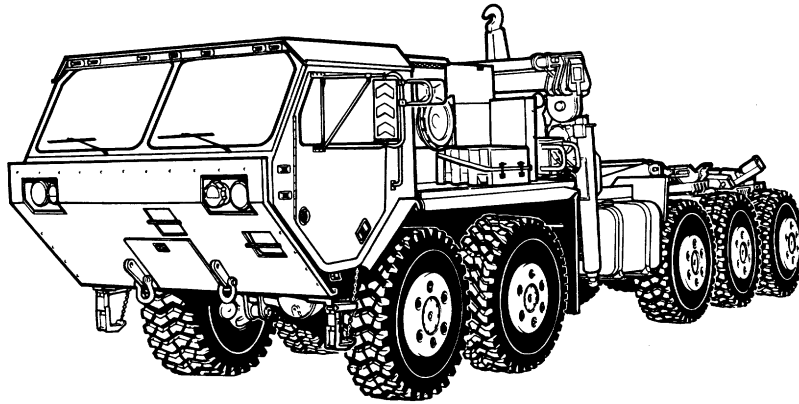
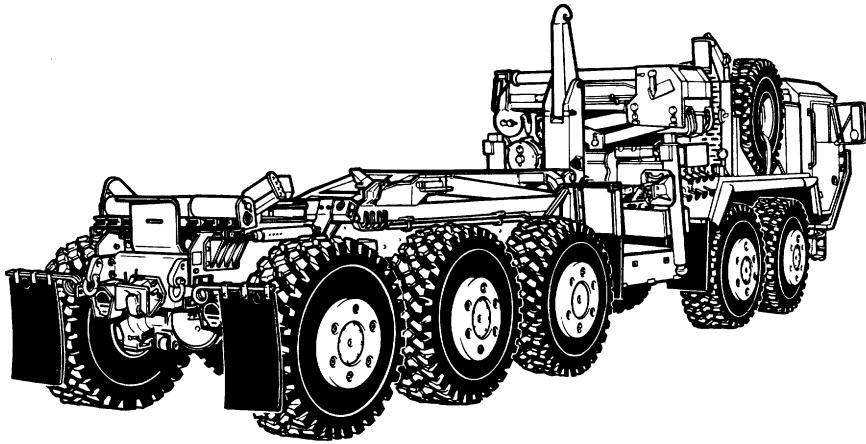
Department of the Army forms and procedures used for equipment maintenance will be those prescribed by DA PAM 738-750, The Army Maintenance Management System (TAMMS) (Maintenance Management UPDATE).

**1-3. CORROSION PREVENTION AND CONTROL (CPC).**

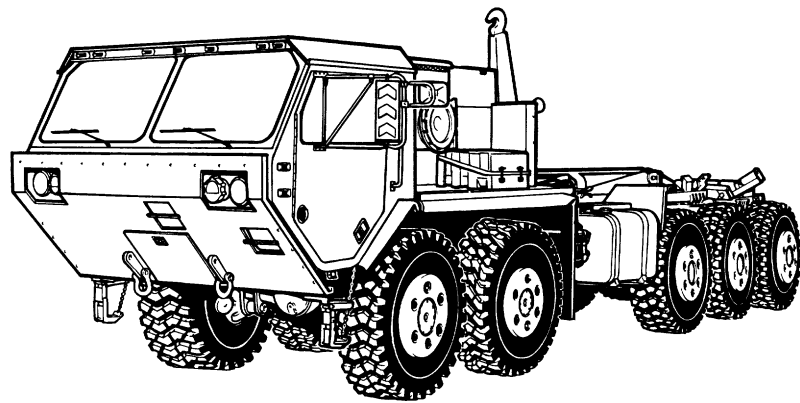
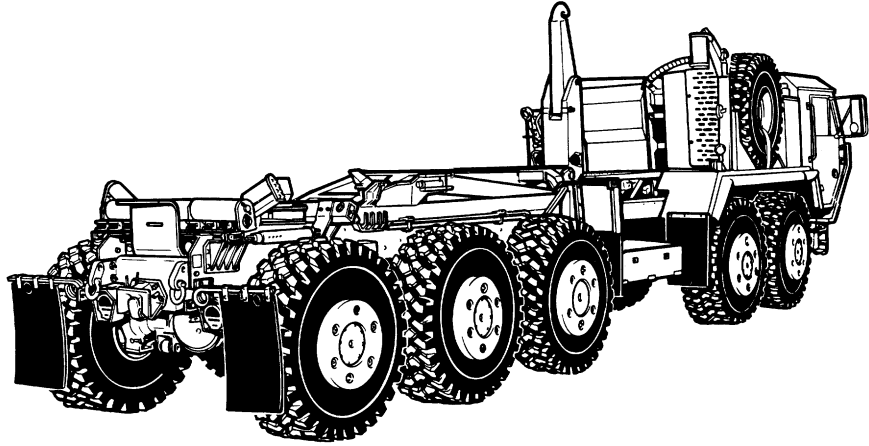
The PLS has a total service life of ten years which allows for extended periods of operation in a corrosive environment. A corrosive environment includes exposure to high humidity, salt spray, road-deicing chemicals, gravel, and atmospheric contamination. No action beyond normal washing and repair of damaged areas is necessary to control corrosion. To prevent moisture accumulation, drain holes are provided on structural and sheet metal areas where necessary. Stowage boxes are provided with seals and baffled drains.

**1-4. DESTRUCTION OF ARMY MATERIEL TO PREVENT ENEMY USE.**

Refer to TM 750-244-6, Procedures for Destruction of Tank Automotive Equipment to Prevent Enemy Use.

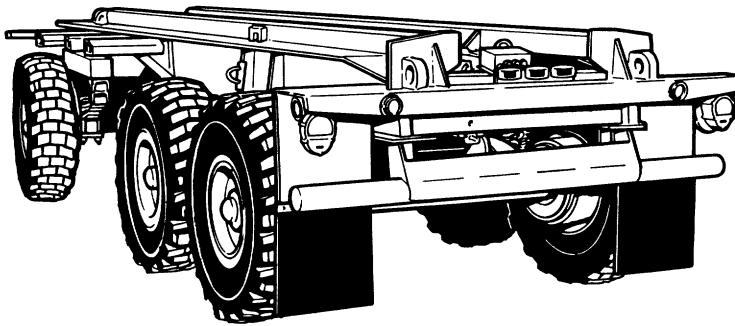
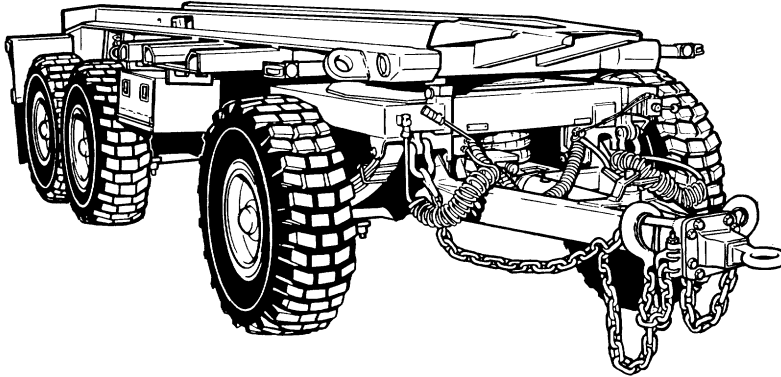


*Figure 1-1. M1074 Palletized Load System Truck (With Crane)*

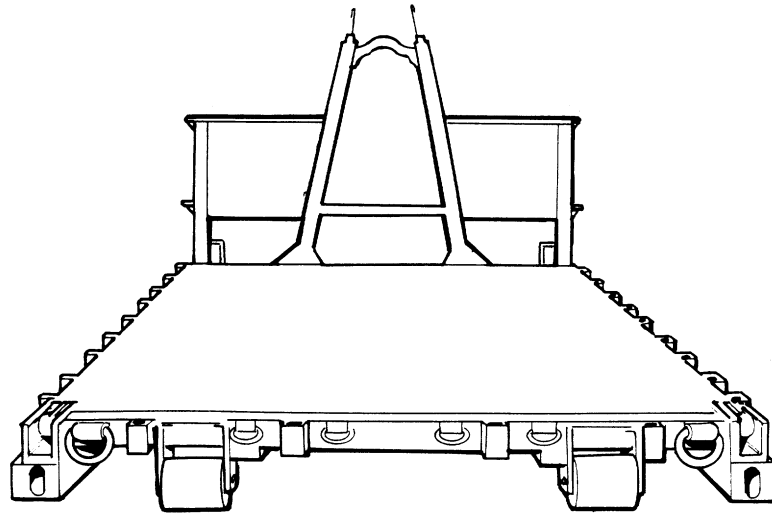
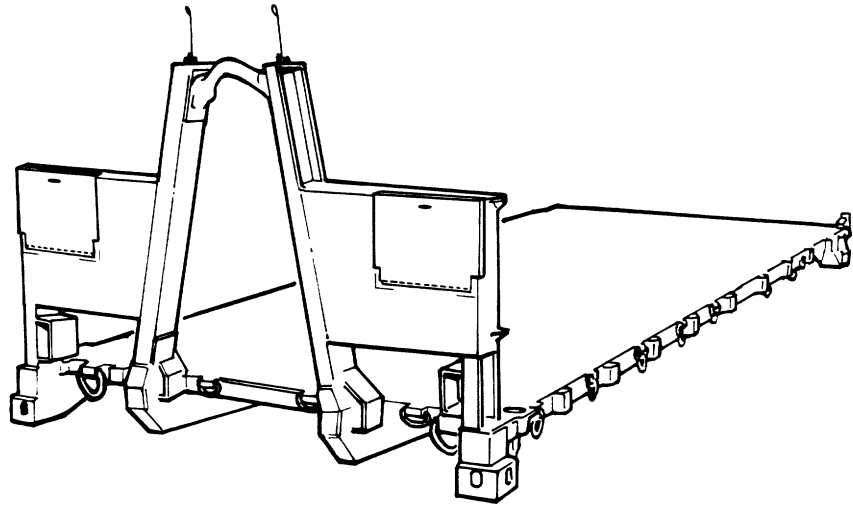


*Figure 1-2. M1075 Palletized Load System Truck (Without Crane)  
(Without Container Handling Unit)*





**Figure 1-3. M1076 Palletized Load System Trailer (PLST)**



*Figure 1-4. M1077 Flatrack*

**1-5. REPORTING EQUIPMENT IMPROVEMENT RECOMMENDATIONS (EIR).**

If your Palletized Load System needs improvement, let us know. Send us an EIR. You, the user, are the only one who can tell us what you don't like about your equipment. Let us know why you don't like the design or performance. Put it on a SF 368 (Product Quality Deficiency Report). Mail it to us at: Commander, U.S. Army Tank-automotive and Armaments Command, ATTN: AMSTA-TR-E-MPA, Warren, MI 48397-5000. We'll send you a reply.

**1-6. WARRANTY INFORMATION.**

The PLS is warranted by Oshkosh Truck Corporation for 12 months. For complete information covering this warranty refer to TB 9-2320-364-15, Warranty Procedures for Truck, Tractor, M1074 and M1075, Palletized Load System (PLS) NSN 2320-01-304-2277 and 2320-01-304-2278.

**1-7. NOMENCLATURE CROSS-REFERENCE LIST.**

This listing includes nomenclature cross-reference list and a list of abbreviations used in this manual.

**a. Nomenclature Cross-Reference List**

Common Name	Official Nomenclature
Engine Coolant	- Antifreeze, ethylene glycol mixture
Cold Start System	- Ether quick start system
Cable	- Wire rope
Glad Hand	- Quick disconnect air coupling
Throttle Pedal	- Throttle control
Service Brake Pedal	- Brake pedal
Jake Brake	- Engine brake

**1-8. LIST OF ABBREVIATIONS.**

AAL	.....	Additional Authorization List
amp	.....	Amperes
AOAP	.....	Army Oil Analysis Program
ATEC	.....	Allison Transmission Electronic Control
BII	.....	Basic Issue Item
C	.....	Centigrade