

OPERATOR'S MANUAL
MULTIPLE INTEGRATED LASER
ENGAGEMENT SYSTEM (MILES)
SIMULATOR SYSTEM, FIRING, LASER: M89
(NSN 1265-01-236-6725)

FOR

M16A1/M16A2 RIFLE
AND
SIMULATOR SYSTEM, FIRING, LASER: M90
(NSN 1265-01-236-6724)

FOR
M249, SQUAD AUTOMATIC WEAPON (SAW)

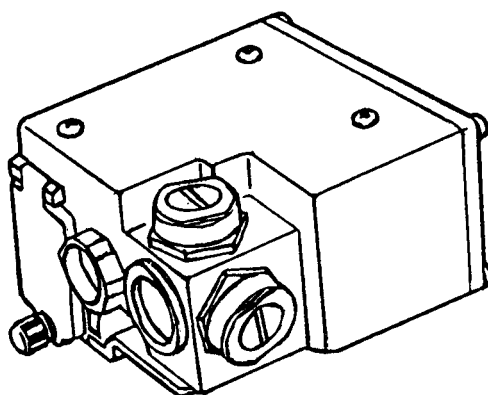

Distribution Statement A: Approved for public release; distribution is unlimited.

HEADQUARTERS, DEPARTMENT OF THE ARMY

February 1989

OPERATOR'S MANUAL
FOR
MULTIPLE INTEGRATED LASER ENGAGEMENT SYSTEM (MILES)
SIMULATOR SYSTEM, FIRING, LASER: M89
(NSN 1265-01-236-6725)
FOR
M16A1/M16A2 RIFLE
AND
SIMULATOR SYSTEM, FIRING, LASER: M90
(NSN 1265-01-236-6724)
FOR
M249, SQUAD AUTOMATIC WEAPON (SAW)

REPORTING ERRORS AND RECOMMENDING IMPROVEMENTS

You can help improve this manual. If you find any mistakes or if you know of a way to improve the procedures, please let us know. Mail your letter, DA Form 2028 (Recommended Changes to Publications and Blank Forms), or DA Form 2028-2 located in back of this manual direct to: Commander U.S. Army Simulation, Training, and Instrumentation Command (STRICOM), ATTN: AMSTI-LSM, 12350 Research Parkway, Orlando, FL 32826-3276. A reply will be furnished to you.

DISTRIBUTION STATEMENT A.

Approved for public release; distribution is unlimited.

TABLE OF CONTENTS

Page

CHAPTER 1	GENERAL INFORMATION	1-1
Section 1.1	Introduction	1-1
Section 1.2	How To Use This Manual	1-1
Section 1.3	Purpose of Equipment	1-1
Section 1.4	Equipment.....	1-2
Section 1.5	List of Terms	1-5
CHAPTER 2	SMALL ARMS TRANSMITTER	2-1
Section 2.1	Introduction	2-1
Section 2.2	Equipment Description.....	2-1
Section 2.3	Limitations of Equipment	2-3
Section 2.4	Inspection and Cleaning	2-3
Section 2.5	Installation.....	2-4
-2.5.1	Battery Installation.....	2-4
-2.5.2	Mounting Brackets	2-5
-2.5.3	Installing the SAT on the SAW.....	2-7
-2.5.4	Installing the SAT on the M16A1.....	2-8
-2.5.5	Installing the SAT on the M16A2.....	2-9
Section 2.6	Operation	2-10
-2.6.1	Blank-Fire Mode	2-10
-2.6.2	Dry-Fire Mode	2-12
Section 2.7	Alignment Using the SAAF	2-14
-2.7.1	Coarse Alignment Procedure	2-18
Section 2.8	Removal.....	2-19

Table of Contents (con't)

	-2.8.1	Removal of the SAT from the SAW	2-19
	-2.8.2	Removal of the SAT from the M16A1	2-19
	-2.8.3	Removal of the SAT from the M16A2	2-20
Section	2.9	Handling and Storage	2-20
CHAPTER	3	MAN-WORN LASER DETECTOR ASSEMBLY	3-1
Section	3.1	Introduction	3-1
Section	3.2	Equipment Description.....	3-1
	-3.2.1	Helmet Harness	3-1
	-3.2.2	Torso Harness.....	3-2
Section	3.3	Limitations of Equipment	3-3
Section	3.4	Inspection and Cleaning	3-3
Section	3.5	Installation.....	3-3
	-3.5.1	Attaching the Helmet Harness	3-4
	-3.5.2	Attaching the Torso Harness.....	3-5
Section	3.6	Operation	3-7
	-3.6.1	Helmet Harness Battery Installation.....	3-8
	-3.6.2	Torso Harness Battery Installation	3-9
	-3.6.3	Testing the MWLD System by a Controller	3-10
	-3.6.3.1	Testing the Torso Harness.....	3-10
	-3.6.3.2	Testing the Helmet Harness.....	3-11
	-3.6.3.3	Testing the Total MWLD System	3-11
	-3.6.4	Modes of Operation.....	3-12
	-3.6.4.1	KILLED	3-12
	-3.6.4.2	NEAR MISS.....	3-12
	-3.6.5	Resetting the MILD System.....	3-13
Section	3.7	Handling and Storage	3-13
CHAPTER	4	SMALL ARMS ALIGNMENT FIXTURE	4-1
Section	4.1	Introduction	4-1
Section	4.2	Equipment Description.....	4-1
Section	4.3	Limitations of Equipment	4-4
Section	4.4	Inspection and Cleaning	4-4
Section	4.5	Operation	4-5
	-4.5.1	Initial Set-up Conditions	4-5
	-4.5.2	Operating SAAF P/N 11835282	4-6
	-4.5.3	Operating SAAF P/N 9353020	4-7
Section	4.6	Handling and Storage	4-7
APPENDIX	A	REFERENCES.....	A-1
APPENDIX	B	COMPONENTS OF END ITEM AND BASIC ISSUE ITEMS LIST	B-1
APPENDIX	C	ADDITIONAL AUTHORIZATION LIST	C-1
APPENDIX	D	EXPENDABLE SUPPLIES AND MATERIALS LIST	D-1

LIST OF ILLUSTRATIONS

<u>FIGURE</u>	<u>TITLE</u>	<u>PAGE</u>
1-1	Infantry System	1-2
1-2	Support Equipment.....	1-3
1-3	Infantry System Equipment Location.....	1-4
2-1	SAT Assembly.....	2-2
2-2	Inspecting and Cleaning the SAT.....	2-3
2-3	SAT Battery Installation.....	2-4

List of Illustrations (con't)

2-4	SAW Mounting Bracket	2-5
2-5	Universal Mounting Bracket	2-6
2-6	Installing the SAT on the SAW Barrel	2-7
2-7	Installing the SAT on the M16A1 Using the Universal Mounting Bracket	2-8
2-8	Installing the SAT on the M16A2 Using the Universal Mounting Bracket.....	2-9
2-9	BLANK-FIRE Attachment (typical)	2-10
2-10	SAT Rear View.....	2-11
2-11	DRY-FIRE Cable Installation.....	2-13
2-12	SAAF Front Panel	2-15
2-13	SAAF Front Panel	2-16
2-14	Laser Adjustor 'Click' Marks.....	2-17
3-1	Helmet Harness Assembly.....	3-1
3-2	Torso Harness Assembly	3-2
3-3	Attaching the Helmet Harness	3-4
3-4	Attaching the Torso Harness to the Web Belt.....	3-5
3-5	Securing Clamp.....	3-5
3-6	Torso Harness Placement.....	3-6
3-7	Torso Harness Attachment	3-7
3-8	Helmet Harness Battery Installation.....	3-8
3-9	Torso Harness Battery Installation	3-9
4-1	Small Arms Alignment Fixture Assembly (P/N 11835282)	4-2
4-2	Small Arms Alignment Fixture Assembly (P/N 9353020)	4-3
4-3	SAAF	4-6

LIST OF TABLES

<u>TABLE</u>	<u>TITLE</u>	<u>PAGE</u>
1-1	Terminology	1-5

CHAPTER 1

GENERAL INFORMATION

1.1 INTRODUCTION

The instructions and procedures contained in this manual are intended for use by operating personnel of the Multiple Integrated Laser Engagement System (MILES) Infantry System.

NOTE

This publication contains application instructions pertaining to the M16A1, M16A2 and M249 SAW for the equipment listed. Do not confuse with earlier equipment identified as Simulator System, Firing, Laser: M60 for M16A1 Rifle (NSN 1265-01-085-1583).

1.2 HOW TO USE THIS MANUAL

Chapter 1 is a general overview of the purpose and identification of the total Infantry System. Each following chapter deals with a particular component of the system and all related information needed by the operator to use that component.

To perform the procedures discussed in this manual, the operating personnel must be able to:

- load and fire blank ammunition
- install a Blank-Fire Attachment (BFA) on the M16A1 and M16A2 rifles and on the M249 Squad Automatic Weapon (SAW)
- requisition basic military equipment through proper channels
- return defective equipment for servicing

It is suggested that this manual be read in its entirety to familiarize the reader with the total system.

1.3 PURPOSE OF EQUIPMENT

The purpose of the Infantry System is to provide realistic combat training exercise without using live ammunition.

The Infantry System is comprised of battery-powered laser transmitters and detector assemblies. When fired, the transmitter sends an invisible beam of radiated energy (laser) toward a target. The target is outfitted with the detector assembly which senses the laser beam and sounds an alarm. The alarm sounds in different tones, indicating whether the target was KILLED or NEAR MISSED by the laser beam.

Support equipment for the Infantry System includes a Controller Gun which is used by the umpire (or Controller) of the training exercise. A Small Arms Alignment Fixture (SAAF) is used to align the transmitter to the weapon sights of the weapon and to verify the operability of the transmitter.

1.4 EQUIPMENT

Figure 1-1 illustrates and identifies the major components and Figure 1-2 the support equipment of the Infantry System. They are the:

- Small Arms Transmitter (SAT) assembly
- Man-Worn Laser Detector (MWLD) assembly, which includes the Helmet and Torso Harnesses
- Controller Gun assembly
- Small Arms Alignment Fixture (SAAF) assembly

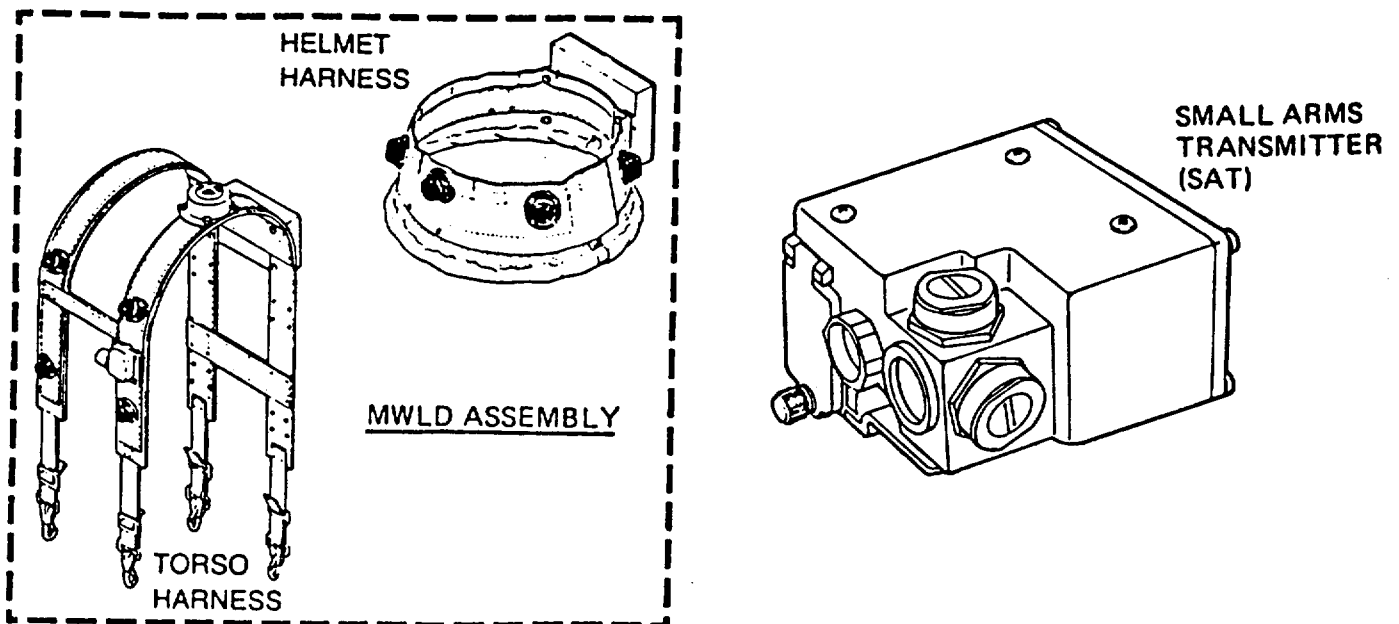

FIGURE 1-1. Infantry System